

# Appendix H

---

Supporting Noise Information



Number	Start Date	Start Time	End Time	Duration	LZeq	LCeq	LAeq	LZSmax	LCSmax	LASmax	LZSmin	LCSmin	LASmin	LZE	LCE
ST-1	11/12/2024	10:49:16 AM	11:04:16 AM	0:15:00	71.3	68.7	60.2	88	87.8	73.2	64.2	60.6	50.7	100.8	98.2
ST-2	11/12/2024	10:28:54 AM	10:43:54 AM	0:15:00	71.8	69.9	61.6	84.1	83.7	77.1	64.6	61	50.7	101.3	99.4
ST-3	11/12/2024	11:37:23 AM	11:52:23 AM	0:15:00	69.9	67	56.4	84.7	84.3	71.8	62.8	59.3	50.5	99.4	96.5
ST-4	11/12/2024	11:09:15 AM	11:24:15 AM	0:15:00	71.5	68.8	59.2	82.2	79.8	66.7	66.9	63.6	53.1	101	98.3
Number	LAE	LZpk	LCpk	LApk	LAS1%	LAS2%	LAS5%	LAS8%	LAS10%	LAS25%	LAS50%	LAS90%	LAS95%	LAS99%	
ST-1	89.7	97.2	97.5	90.8	70.3	69.4	67.5	65.5	64.4	58.3	54.1	52	51.7	51.2	
ST-2	91.1	96.6	97.3	89.1	72.8	71.8	68.7	66.4	64.8	59.1	54.1	52	51.4	51	
ST-3	85.9	98.1	97	91.9	66.2	63.8	61.1	59.4	58.4	55	53.4	51.8	51.4	51.1	
ST-4	88.7	91.5	89.4	90	64	63.3	62.4	61.7	61.4	60.2	58.7	55.5	54.9	54.3	

### LT-1 - November 13 - 14, 2024

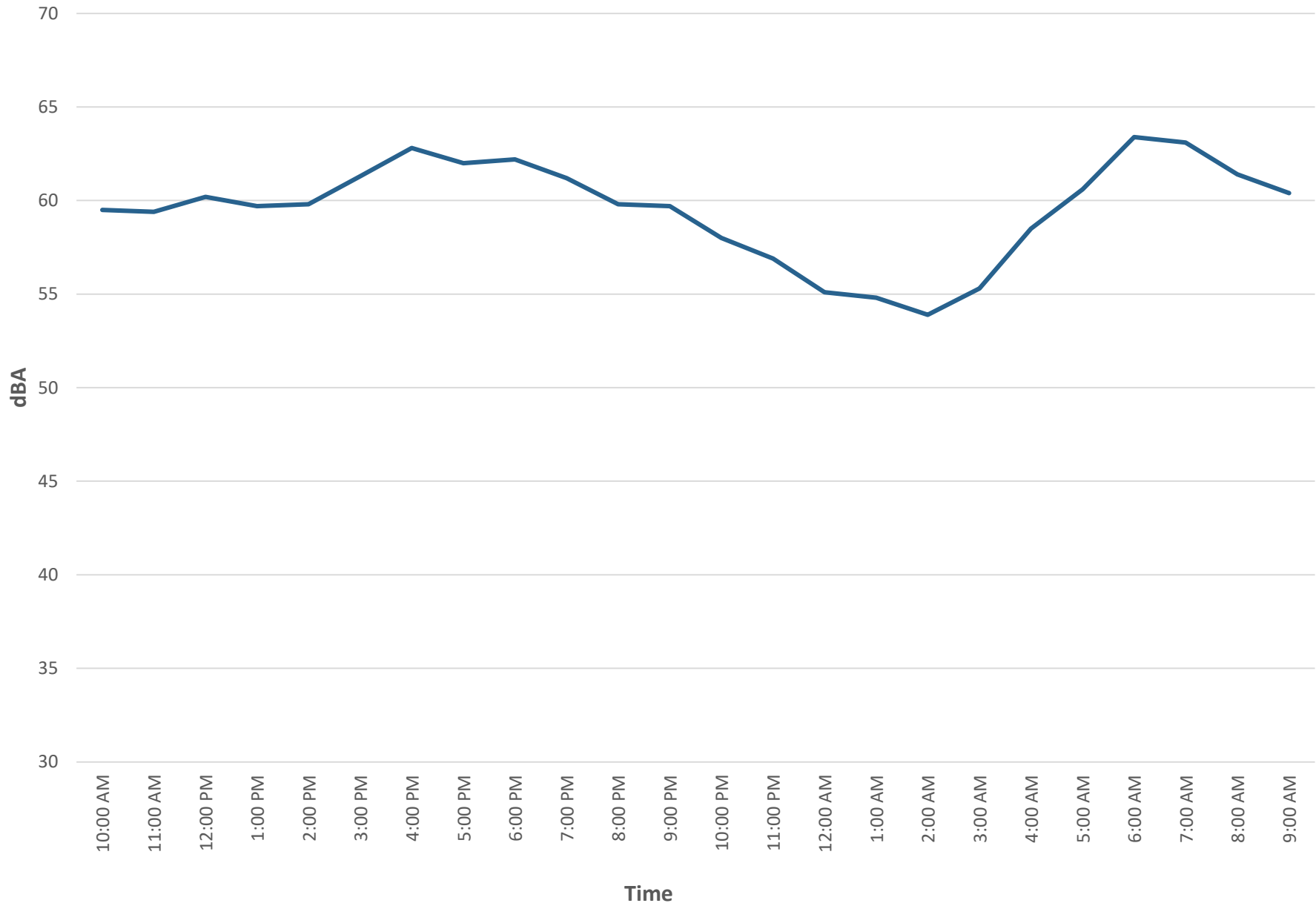

### LT-2 - November 13 - 14, 2024

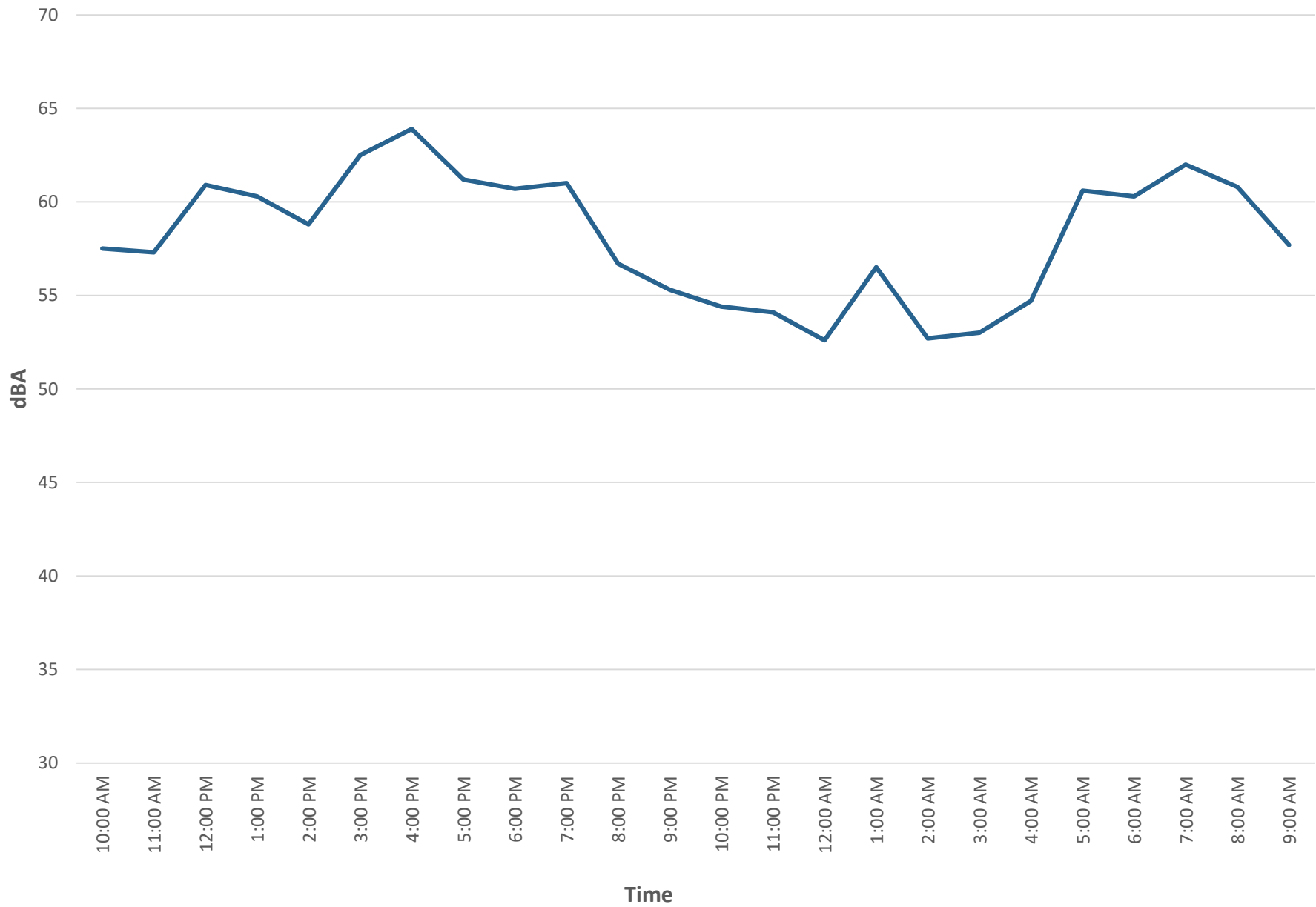

**24ABA4**  
**Base Series 14 Air Conditioner**  
**with Puron Refrigerant**  
**Sizes 18 to 60 (1 – 1/2 to 5 Nominal Tons)**



Turn to the Experts.™

## Product Data



Carrier's Air Conditioners with Puron® refrigerant provide a collection of features unmatched by any other family of equipment. The 24ABA has been designed utilizing Carrier's Puron refrigerant. The environmentally sound refrigerant allows you to make a responsible decision in the protection of the earth's ozone layer. Carrier's air conditioning system with Puron refrigerant meets the Energy Star® guidelines for energy efficiency.

### INDUSTRY LEADING FEATURES / BENEFITS

#### Efficiency

- 14 SEER/11 EER
- Microtube Technology™ refrigeration system
- Indoor air quality accessories available

#### Sound

- Sound level as low as 76 dBA

#### Comfort

- System supports Thermidistat™ or standard thermostat controls

#### Reliability

- Puron® refrigerant - environmentally sound, won't deplete the ozone layer and low lifetime service cost.
- Front-seating service valves
- Scroll compressor
- Internal pressure relief valve
- Internal thermal overload
- Filter drier
- Balanced refrigeration system for maximum reliability

#### Durability

WeatherArmor™ protection package:

- Solid, Durable sheet metal construction
- Dense wire coil guard
- Baked-on, complete coverage, powder paint

#### Applications

- Long-line - up to 250 feet (76.20 m) total equivalent length, up to 200 feet (60.96 m) condenser above evaporator, or up to 80 ft. (24.38 m) evaporator above condenser (See Longline Guide for more information.)
- Low ambient (down to -20°F/-28.9°C) with accessory kit

#### Warranty

- 5 year limited compressor warranty
- 5 year limited parts warranty

## MODEL NUMBER NOMENCLATURE

1	2	3	4	5	6	7	8	9	10	11	12	13
N	N	A	A	A/N	N	N	N	A/N	A/N	A/N	N	N
2	4	A	B	A	4	3	6	A	0	0	3	0
Product Series	Product Family	Tier	Major Series	SEER	Cooling Capacity	Variations	Open	Open	Voltage	Series		
24=AC	A=RES AC	B=Base	A=Puron	4=14 SEER		A=Standard	0=Not Defined	0=Not Defined	3=208/230-1	0 = Original Series		

24ABA4



This product has been designed and manufactured to meet Energy Star® criteria for energy efficiency when matched with appropriate coil components. However, proper refrigerant charge and proper air flow are critical to achieve rated capacity and efficiency. Installation of this product should follow all manufacturing refrigerant charging and air flow instructions. Failure to confirm proper charge and air flow may reduce energy efficiency and shorten equipment life.

## STANDARD FEATURES

FEATURE	18	24	30	36	42	48	60
Puron Refrigerant	X	X	X	X	X	X	X
Maximum SEER Rating	15	15	15	15	15.5	15.5	14.5
Scroll Compressor	X	X	X	X	X	X	X
Dense Wire Coil Guard	X	X	X	X	X	X	X
Field Installed Filter Drier	X	X	X	X	X	X	X
Front Seating Service Valves	X	X	X	X	X	X	X
Internal Pressure Relief Valve	X	X	X	X	X	X	X
Internal Thermal Overload	X	X	X	X	X	X	X
Long Line capability	X	X	X	X	X	X	X
Low Ambient capability with Kit	X	X	X	X	X	X	X

## PHYSICAL DATA

UNIT SIZE – VOLTAGE, SERIES	18–31	24–31	30–31	36–31	42–32	48–32	60–32
Operating Weight lb (kg)	171 (77.56)	185 (83.92)	188 (85.28)	191 (86.64)	225 (102.10)	231 (104.78)	272 (123.38)
Shipping Weight lb (kg)	199 (90.27)	214 (97.07)	217 (98.43)	225 (102.06)	263 (119.29)	269 (122.02)	310 (140.61)
<b>Compressor Type</b>	Scroll						
<b>REFRIGERANT</b>	Puron® (R-410A)						
Control	TXV (Puron® Hard Shutoff)						
Charge lb (kg)	5.7 (2.59)	7.25 (3.29)	7.1 (3.22)	7.25 (3.29)	8.7 (3.95)	9.5 (4.31)	11.4 (5.17)
<b>COND FAN</b>	Propeller Type, Direct Drive						
Air Discharge	Vertical						
Air Qty (CFM)	2235	2615	3170	3800	3800	3800	4050
Motor HP	1/12	1/10	1/5	1/5	1/5	1/5	1/5
Motor RPM	800	1100	1100	800	800	800	800
<b>COND COIL</b>							
Face Area (Sq ft)	19.40	23.71	23.71	22.63	25.15	25.15	25.15
Fins per In.	25	25	25	25	25	25	20
Rows	1	1	1	1	1	1	2
Circuits	3	4	4	5	6	7	7
<b>VALVE CONNECT. (In. ID)</b>							
Vapor	5/8	5/8	3/4	3/4	7/8	7/8	7/8
Liquid	3/8	3/8	3/8	3/8	3/8	3/8	3/8
<b>REFRIGERANT TUBES* (In. OD)</b>							
Vapor (0–80 Ft Tube Length)	5/8		3/4		7/8		1–1/8
Liquid (0–80 Ft Tube Length)	3/8						

\* For tubing sets between 80 and 200 ft. (24.38 and 60.96 m) horizontal or 20 ft. (6.09 m) vertical differential, consult the Longline Guideline.

**Note:** See unit Installation Instruction for proper installation.

## VAPOR LINE SIZING AND COOLING CAPACITY LOSS 1-STAGE AIR CONDITIONER APPLICATIONS

**LONG LINE APPLICATION:** An application is considered "Long line" when the total equivalent tubing length exceeds 80 ft. (24.38 m) or when there is more than 20 ft. (6.09 m) vertical separation between indoor and outdoor units. These applications require additional accessories and system modifications for reliable system operation. The maximum allowable total equivalent length is 250 ft. (76.2 m). The maximum vertical separation is 200 ft. (60.96 m)

when outdoor unit is above indoor unit, and 80 ft. (24.38 m) when the outdoor unit is below the indoor unit. Refer to Accessory Usage Guideline below for required accessories. See Longline Application Guideline for required piping and system modifications. Also, refer to the table below for the acceptable vapor tube diameters based on the total length to minimize the cooling capacity loss.

Unit Nominal Size (Btuh)	Acceptable Vapor Line Diameters (In.) OD	Cooling Capacity Loss (%) Total Equivalent Line Length ft. (m)										
		Standard Application			Long Line Application Requires Accessories							
		25 (7.62)	50 (15.24)	80 (24.38)	80+ (24.38+)	100 (30.48)	125 (38.10)	150 (45.72)	175 (53.34)	200 (60.96)	225 (68.58)	250 (76.2)
18,000 1-Stage Puron AC	1/2	1	2	3	3	4	6	7	8	9	10	12
	5/8	0	0	1	1	1	1	2	2	3	3	3
24,000 1-Stage Puron AC	5/8	0	1	1	1	2	3	3	4	4	5	6
	3/4	0	0	0	0	0	1	1	1	1	1	2
	7/8	0	0	0	0	0	0	0	0	0	0	1
30,000 1-Stage Puron AC	5/8	1	2	3	3	3	4	5	6	7	8	9
	3/4	0	0	1	1	1	1	2	2	2	3	3
	7/8	0	0	0	0	0	1	1	1	1	1	1
36,000 1-Stage Puron AC	5/8	1	2	4	4	5	6	7	9	10	11	13
	3/4	0	0	1	1	1	2	2	3	3	4	4
	7/8	0	0	0	0	0	1	1	1	1	2	2
42,000 1-Stage Puron AC	3/4	0	1	2	2	2	3	4	4	5	6	6
	7/8	0	0	1	1	1	1	2	2	2	3	3
	1–1/8	0	0	0	0	0	0	0	0	0	0	1
48,000 1-Stage Puron AC	3/4	0	1	2	2	3	4	5	5	6	7	8
	7/8	0	0	1	1	1	2	2	2	3	3	4
	1–1/8	0	0	0	0	0	0	0	0	1	1	1
60,000 1-Stage Puron AC	3/4	1	2	4	4	5	6	7	9	10	11	12
	7/8	0	1	2	2	2	3	4	4	5	5	6
	1–1/8	0	0	0	0	1	1	1	1	1	1	2

Standard Length = 80 ft. (24.38 m) or less total equivalent length

Applications in this area are long line. Accessories are required as shown recommended on Long Line Application Guidelines

Applications in this area may have height restrictions that limit allowable total equivalent length, when outdoor unit is below indoor unit. See Long Line Application Guidelines

## ACCESSORY THERMOSTATS

THERMOSTAT / SUBBASE PKG.	DESCRIPTION
TSTATCCPRH01-B	Thermostat Control – Programmable / Non-Programmable Thermostat with Humidity control
TSTATCCPAC01-B	Thermostat – Auto Changeover, 7-Day Programmable, °F/°C, 1-Stage Heat, 1-Stage Cool
TSTATCCNAC01-C	Thermostat – Auto Changeover, Non-Programmable, °F/°C, 1-Stage Heat, 1-Stage Cool
TSTATCCBAC01-B	Builder's Thermostat – Manual Changeover, Non-Programmable, °F/°C, 1-Stage Heat, 1-Stage Cool
TSTATCCSEN01-B	Outdoor Air Temperature Sensor
TSTATXXBBP01	Backplate for Builder's Thermostat
TSTATXXNBP01	Backplate for Non-Programmable Thermostat
TSTATXXBP01	Backplate for Programmable Thermostat
TSTATXXCNV10	Thermostat Conversion Kit (4 to 5 wires) – 10 Pack
TB-PAC-01	Base Series Programmable AC Stat
TB-NAC-01	Base Series Non-programmable AC Stat

## ACCESSORIES

KIT NUMBER	DESCRIPTION	18-31	24-31	30-31	36-31	42-32	48-32	60-32
HC32GE234	MOTOR FAN BALL BEARING	X						
HC34GE239	MOTOR FAN BALL BEARING		X	X				
HC40GE226	MOTOR FAN BALL BEARING				X		X	
HC38GE219	MOTOR FAN BALL BEARING					X		
HC40GE228	MOTOR FAN BALL BEARING							X
KAACH1201AAA	CRANKCASE HTR					X	X	X
KAACH1401AAA	CRANKCASE HTR	X	X	X	X			
KAACS0201PTC	START ASSIST PTC	X	X	X	X	X	X	X
KAFT0101AAA	FREEZE THERMOSTAT	X	X	X	X	X	X	X
KAHI0501PUR	HIGH PRESSURE SWITCH	X	X	X	X	X	X	X
KAALP0401PUR	LOW PRESSURE SWITCH	X	X	X	X	X	X	X
KAATD0101TDR	TIME DELAY RELAY	X	X	X	X	X	X	X
KAWS0101AAA	WINTER START	X	X	X	X	X	X	X
KSACY0101AAA	CYCLE PROTECTOR	X	X	X	X	X	X	X
KSAHS1701AAA	HARD START (CAP / RELAY)	X	X	X	X	X	X	X
KSALA0301410	LOW AMBIENT PSW	X	X	X	X	X	X	X
KSALA0601AAA	MOTORMASTER 230V	X	X	X	X	X	X	X
KSASF0101AAA	SUPPORT FEET	X	X	X	X	X	X	X
KSASH0601COP	SOUND HOOD	X	X	X	X	X	X	
KSASH2101COP	SOUND HOOD							X
KSATX0201PUR	TXV PURON HSO	X	X	X				
KSATX0301PUR	TXV PURON HSO				X	X		
KSATX0401PUR	TXV PURON HSO						X	
KSATX0501PUR	TXV PURON HSO							X

x = Accessory

## ACCESSORY USAGE GUIDELINE

ACCESSORY	REQUIRED FOR LOW-AMBIENT COOLING APPLICATIONS (Below 55°F/12.8°C)	REQUIRED FOR LONG LINE APPLICATIONS* (Over 80 ft./24.38 m)	REQUIRED FOR SEA COAST APPLICATIONS (Within 2 miles/3.22 km)
Ball Bearing Fan Motor	Yes†	No	No
Compressor Start Assist Capacitor and Relay	Yes†	Yes	No
Crankcase Heater	Yes†	Yes	No
Evaporator Freeze Thermostat	Yes†	No	No
Hard Shut-Off TXV	Yes†	Yes	Yes
Liquid Line Solenoid Valve	No	See Long Line Application Guideline	No
Motor Master® Control or Low-ambient Pressure Switch	Yes†	No	No
Support Feet	Recommended	No	Recommended

\* For tubing line sets between 80 and 200 ft. (24.38 and 60.96 m) and/or 20 ft. (6.09 m) vertical differential, refer to Residential Split-System Longline Application Guideline.

† Required for Low-Ambient Controller (full modulation feature) MotorMaster® Control.

### Accessory Description and Usage (Listed Alphabetically)

#### 1. Ball-Bearing Fan Motor

A fan motor with ball bearings which permits speed reduction while maintaining bearing lubrication.

Usage Guideline:

Required on all units when MotorMaster® —

#### 2. Compressor Start Assist - Capacitor and Relay

Start capacitor and relay gives a "hard" boost to compressor motor at each start up.

Usage Guideline:

Required for reciprocating compressors in the following applications:

- Long line
- Low ambient cooling
- Hard shut off expansion valve on indoor coil
- Liquid line solenoid on indoor coil

Required for single-phase scroll compressors in the following applications:

- Long line
- Low ambient cooling

Suggested for all compressors in areas with a history of low voltage problems.

#### 3. Compressor Start Assist — PTC Type

Solid state electrical device which gives a "soft" boost to the compressor at each start-up.

Usage Guideline:

Suggested in installations with marginal power supply.

#### 4. Crankcase Heater

An electric resistance heater which mounts to the base of the compressor to keep the lubricant warm during off cycles. Improves compressor lubrication on restart and minimizes the chance of liquid slugging.

Usage Guideline:

- Required in low ambient cooling applications.
- Required in long line applications.
- Suggested in all commercial applications.

#### 5. Cycle Protector

The cycle protector is designed to prevent compressor short cycling. This control provides an approximate 5-minute delay after power to the compressor has been interrupted for any reason, including power outage, protector control trip, thermostat jiggling, or normal cycling.

#### 6. Evaporator Freeze Thermostat

An SPST temperature-actuated switch that stops unit operation when evaporator reaches freeze-up conditions.

Usage Guideline:

Required when low ambient kit has been added.

#### 7. Low-Ambient Pressure Switch Kit

A long life pressure switch which is mounted to outdoor unit service valve. It is designed to cycle the outdoor fan motor in order to maintain head pressure within normal operating limits (approximately 100 psig to 225 psig). The control will maintain working head pressure at low-ambient temperatures down to 0°F/-17.78°C when properly installed.

Usage Guideline:

A Low-Ambient Pressure Switch or MotorMaster® Low-Ambient Controller must be used when cooling operation is used at outdoor temperatures below 55°F (12.8°C).

#### 8. MotorMaster® Low-Ambient Controller

A fan-speed control device activated by a temperature sensor, designed to control condenser fan motor speed in response to the saturated, condensing temperature during operation in cooling mode only. For outdoor temperatures down to -20°F (-28.9°C), it maintains condensing temperature at 100°F ±10°F (37.8°C ± 11°C).

Usage Guideline:

A MotorMaster® Low Ambient Controller or Low-Ambient Pressure Switch must be used when cooling operation is used at outdoor temperatures below 55°F (12.8°C).

Suggested for all commercial applications.

#### 9. Outdoor Air Temperature Sensor

Designed for use with Carrier Thermostats listed in this publication. This device enables the thermostat to display the outdoor temperature. This device also is required to enable special thermostat features such as auxiliary heat lock out.

Usage Guideline:

Suggested for all Carrier thermostats listed in this publication.

## Accessory Description and Usage (Listed Alphabetically) (Continued)

### 10. Sound Hood

Wraparound sound reducing cover for the compressor. Reduces the sound level by about 2 dBA.

Usage Guideline:

Suggested when unit is installed closer than 15 ft (4.57 m) to quiet areas, bedrooms, etc.

Suggested when unit is installed between two houses less than 10 ft (3.05 m) apart.

### 11. Support Feet

Four stick-on plastic feet that raise the unit 4 in. (101.6 mm) above the mounting pad. This allows sand, dirt, and other debris to be flushed from the unit base, minimizing corrosion.

Usage Guideline:

Suggested in the following applications:

Coastal installations.

Windy areas or where debris is normally circulating.

Rooftop installations.

For improved sound ratings.

### 12. Thermostatic Expansion Valve (TXV)

A modulating flow-control valve which meters refrigerant liquid flow rate into the evaporator in response to the superheat of the refrigerant gas leaving the evaporator.

Kit includes valve, adapter tubes, and external equalizer tube. Hard shut off types are available.

**NOTE:** When using a hard shut off TXV with single phase reciprocating compressors, a Compressor Start Assist Capacitor and Relay is required.

Usage Guideline:

Required to achieve ARI ratings in certain equipment combinations. Refer to combination ratings.

Hard shut off TXV or LLS required in air conditioner long line applications.

Required for use on all zoning systems.

### 13. Time-Delay Relay

An SPST delay relay which briefly continues operation of indoor blower motor to provide additional cooling after the compressor cycles off.

**NOTE:** Most indoor unit controls include this feature. For those that do not, use the guideline below.

Usage Guideline:

For improved efficiency ratings for certain combinations of indoor and outdoor units. Refer to ARI Unitary Directory.

### 14. Winter Start Control

This control is designed to alleviate nuisance opening of the low-pressure switch by bypassing it for the first 3 minutes of operation.

## ELECTRICAL DATA

UNIT SIZE	V/PH	OPER VOLTS*		COMPR		FAN	MCA	MIN WIRE SIZE† 60° C	MIN WIRE SIZE† 75° C	MAX LENGTH (FT)‡ 60° C	MAX LENGTH (FT)‡ 75° C	MAX FUSE** or BRK AMPS
		MAX	MIN	LRA	RLA	FLA						
18-31	208/230/1-60	253	197	48.0	9.0	0.5	11.7	14	14	67	64	15
24-31				58.3	13.5	0.7	17.6	14	14	45	43	25
30-31				73.0	14.1	1.1	18.7	14	14	42	40	30
36-31				79.0	16.7	1.2	22.0	12	12	57	54	35
42-32				112.0	17.9	1.2	23.6	10	10	85	80	40
48-32				117.0	21.8	1.2	28.4	10	10	70	67	40
60-32				134.0	26.4	1.2	34.2	8	8	91	86	50

\* Permissible limits of the voltage range at which the unit will operate satisfactorily

† If wire is applied at ambient greater than 30° C (86° F), consult table 310-16 of the NEC (ANSI/NFPA 70). The ampacity of non-metallic-sheathed cable (NM), trade name ROMEX, shall be that of 60° C conditions, per the NEC (ANSI/NFPA 70) Article 336-26. If other than uncoated (no-plated), 60 or 75° C insulation, copper wire (solid wire for 10 AWG or smaller, stranded wire for larger than 10 AWG) is used, consult applicable tables of the NEC (ANSI/NFPA 70).

‡ Length shown is as measured 1 way along wire path between unit and service panel for voltage drop not to exceed 2%.

\*\* Time-Delay fuse.

FLA - Full Load Amps

LRA - Locked Rotor Amps

MCA - Minimum Circuit Amps

RLA - Rated Load Amps

NOTE: Control circuit is 24-V on all units and requires external power source. Copper wire must be used from service disconnect to unit. All motors/compressors contain internal overload protection.

## SOUND POWER

UNIT SIZE - VOLTAGE, SERIES	STANDARD RATING (dBA)	TYPICAL OCTAVE BAND SPECTRUM (dB, without tone adjustment)						
		125	250	500	1000	2000	4000	8000
18-31	76	56.0	60.0	65.0	72.0	65.0	60.5	53.5
24-31	76	52.5	62.5	66.0	69.5	66.5	62.0	57.0
30-31	76	53.5	64.5	69.0	70.0	68.5	66.0	59.5
36-31	76	52.0	60.0	65.5	69.5	64.0	63.0	56.0
42-32	77	55.0	62.0	66.0	70.5	65.5	60.0	54.0
48-32	78	51.5	62.0	67.5	73.5	69.0	64.5	62.0
60-32	78	57.0	62.5	69.0	73.0	66.0	62.0	57.5

## SOUND POWER WITH ACCESSORY SOUND HOOD

UNIT SIZE - VOLTAGE, SERIES	STANDARD RATING (dBA)	TYPICAL OCTAVE BAND SPECTRUM (dB, without tone adjustment)						
		125	250	500	1000	2000	4000	8000
18-31	74	56.0	60.0	65.0	69.0	63.0	60.0	52.5
24-31	74	52.0	62.0	66.5	68.5	66.0	61.0	56.5
30-31	75	53.5	64.5	69.0	69.5	68.0	65.5	59.0
36-31	75	52.0	62.0	65.5	67.5	63.0	61.0	53.5
42-32	74	55.0	61.5	65.0	68.5	65.0	59.0	52.0
48-32	76	53.0	61.5	67.5	72.0	68.0	61.5	59.0
60-32	75	57.0	62.5	68.5	71.0	65.0	60.5	58.5

## CHARGING SUBCOOLING (TXV-TYPE EXPANSION DEVICE)

UNIT SIZE - VOLTAGE, SERIES	REQUIRED SUBCOOLING °F (°C)
18-31	10 (5.6)
24-31	11 (6.1)
30-31	8 (4.4)
36-31	10 (5.6)
42-32	8 (4.4)
48-32	8 (4.4)
60-32	9 (5.0)

DIMENSIONS

UNIT	SERIES	ELECTRICAL CHARACTERISTICS				A	B	C	D	E	F	G	H	J	K	L	M	N	P	OPERATING WEIGHT	SHIPPING WEIGHT	SHIPPING DIMENSIONS (L x W x H)	
24ABA418	1	X	0	0	0	31 3/16"	35 3/4"	3 3/4"	5/8"	6 9/16"	24 11/16"	9 1/8"	5/16"	3"	2 13/16"	1/2"	16 1/4"	16"	16 5/8"	171#	199#	32 3/8" X 35 1/2" X 39 3/8"	
24ABA424	1	X	0	0	0	31 3/16"	42 1/2"	3 3/4"	5/8"	6 9/16"	24 11/16"	9 1/8"	5/16"	3"	2 13/16"	1/2"	16"	16"	19"	185#	214#	32 3/8" X 35 1/2" X 46 3/16"	
24ABA430	1	X	0	0	0	31 3/16"	42 1/2"	3 3/4"	3/4"	6 9/16"	24 11/16"	9 1/8"	5/16"	3"	2 13/16"	1/2"	14 7/8"	15 1/4"	19 3/8"	188#	217#	32 3/8" X 35 1/2" X 46 3/16"	
24ABA436	1	X	0	0	0	35"	35 3/4"	3 3/4"	3/4"	6 9/16"	28 7/16"	9 1/8"	5/16"	3"	2 13/16"	1/2"	18 1/4"	18 1/2"	17 1/2"	191#	225#	36 1/8" X 39 5/16" X 39 3/8"	
24ABA442	1	X	0	0	0	35"	45 15/16"	3 7/8"	7/8"	6 9/16"	28 7/16"	9 1/8"	5/16"	3"	2 15/16"	5/8"	18 3/4"	17"	20 7/8"	237#	272#	36 1/8" X 39 5/16" X 49 9/16"	
	2	X	0	0	0	35"	39 1/8"	3 7/8"	7/8"	6 9/16"	28 7/16"	9 1/8"	5/16"	3"	2 15/16"	5/8"	18 1/2"	16 1/4"	16 1/2"	225#	263#	36 1/8" X 39 5/16" X 42 3/4"	
24ABA448	1	X	0	0	0	35"	32 5/16"	3 7/8"	7/8"	6 9/16"	28 7/16"	9 1/8"	5/16"	3"	2 15/16"	5/8"	17 3/4"	18 3/4"	15 1/2"	239#	272#	36 1/8" X 39 5/16" X 35 15/16"	
	2	X	0	0	0	35"	39 1/8"	3 7/8"	7/8"	6 9/16"	28 7/16"	9 1/8"	5/16"	3"	2 15/16"	5/8"	17 1/2"	16 1/2"	15"	231#	269#	36 1/8" X 39 5/16" X 42 3/4"	
24ABA460	1	X	0	0	0	35"	45 15/16"	3 7/8"	7/8"	6 9/16"	28 7/16"	9 1/8"	5/16"	3"	2 15/16"	5/8"	17 7/8"	18 5/8"	20 1/4"	295#	330#	36 1/8" X 39 5/16" X 49 9/16"	
	2	X	0	0	0	35"	39 1/8"	3 7/8"	7/8"	6 9/16"	28 7/16"	9 1/8"	5/16"	3"	2 15/16"	5/8"	16 1/2"	17"	16 1/4"	272#	310#	36 1/8" X 39 5/16" X 42 3/4"	

208-230-160	230-160	208/230-3-60	460-3-60
-------------	---------	--------------	----------

X = YES  
O = NO

NOTES:

1. ALLOW 30" CLEARANCE TO SERVICE SIDE OF UNIT, 48" ABOVE UNIT, 6" ON ONE SIDE, 12" ON REMAINING SIDE, AND 24" BETWEEN UNITS FOR PROPER AIRFLOW.
2. MINIMUM OUTDOOR OPERATING AMBIENT IN COOLING MODE IS 55°F, MAX. 125°F.
3. SERIES DESIGNATION IS THE 13TH POSITION OF THE UNIT MODEL NUMBER.
4. CENTER OF GRAVITY 

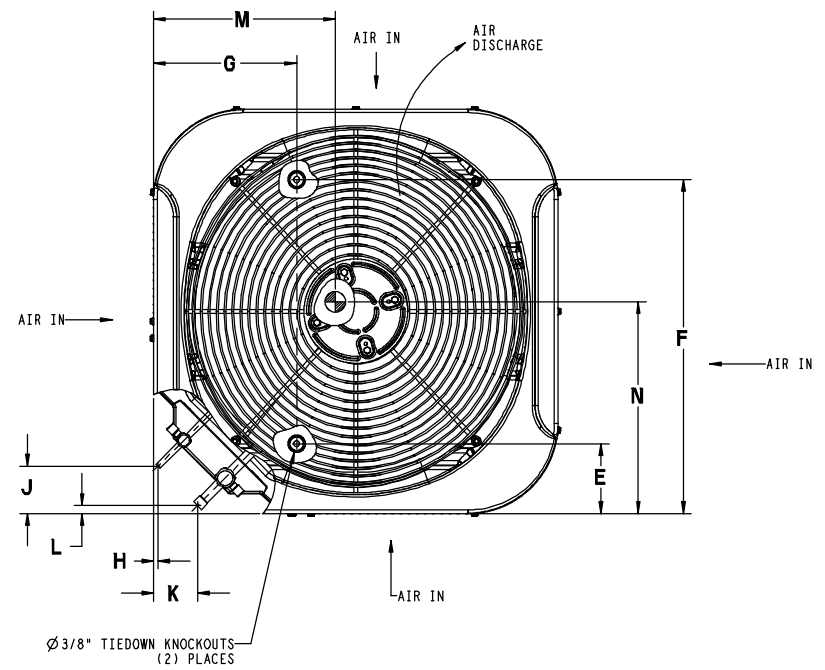
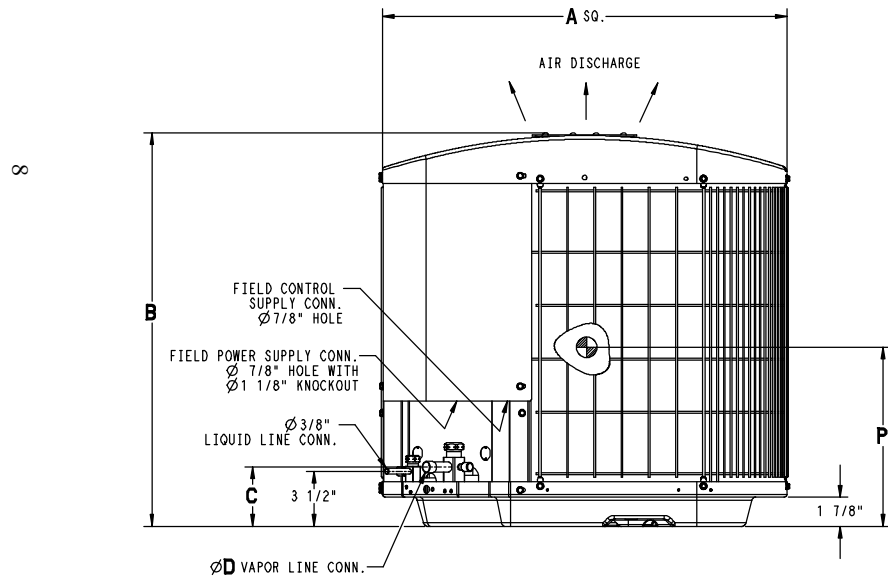

UNIT SIZE	MINIMUM MOUNTING PAD DIMENSIONS
-	26" X 26"
18, 24, 30	31 1/2" X 31 1/2"
36, 42, 48, 60	35" X 35"

# COMBINATION RATINGS

Unit Size – Voltage, Series	Indoor Model	Total Cap. BTUH	Factory Supplied Enhancement	SEER		EER	Furnace Model
				Standard Rating	TDR†		
18–31	*CAP**2414A**	18,000	TXV		14.00	11.5	
	CAP**1814A**	17,600	TDR&TXV	15.00		12.50	58CV(A,X)070–12
	CAP**1814A**	17,800	TXV		13.50	11.20	
	CAP**2414A**	17,900	TDR&TXV	15.00		13.00	58CV(A,X)070–12
	CAP**2417A**	17,900	TDR&TXV	15.00		13.00	58CV(A,X)090–16
	CAP**2417A**	17,900	TDR&TXV	15.00		13.00	58MVB060–14
	CAP**2417A**	17,900	TDR&TXV	15.00		13.00	58UVB060–14
	CAP**2417A**	18,000	TXV		14.00	11.50	
	CNPF*2418A**	18,000	TXV		13.50	11.20	
	CNPH*2417A**	17,900	TDR&TXV	15.00		13.00	58CV(A,X)070–12
	CNPH*2417A**	17,900	TDR&TXV	15.00		13.00	58CV(A,X)090–16
	CNPH*2417A**	17,900	TDR&TXV	15.00		13.00	58MVB040–14
	CNPH*2417A**	17,900	TDR&TXV	15.00		13.00	58MVB060–14
	CNPH*2417A**	17,900	TDR&TXV	15.00		13.00	58MVB080–14
	CNPH*2417A**	18,000	TXV		13.50	11.20	
	CNPV*1814A**	17,600	TDR&TXV	15.00		12.50	58CV(A,X)070–12
	CNPV*1814A**	17,800	TXV		13.50	11.20	
	CNPV*2414A**	17,900	TDR&TXV	15.00		13.00	58CV(A,X)070–12
	CNPV*2414A**	18,000	TXV		14.00	11.50	
	CNPV*2417A**	17,900	TDR&TXV	15.00		13.00	58CV(A,X)090–16
	CNPV*2417A**	17,900	TDR&TXV	15.00		13.00	58MVB060–14
	CNPV*2417A**	18,000	TXV		13.50	11.20	
	CSPH*2412A**	17,900	TDR&TXV	15.00		13.00	58CV(A,X)070–12
	CSPH*2412A**	17,900	TDR&TXV	15.00		13.00	58CV(A,X)090–16
	CSPH*2412A**	17,900	TDR&TXV	15.00		13.00	58MVB040–14
	CSPH*2412A**	17,900	TDR&TXV	15.00		13.00	58MVB060–14
	CSPH*2412A**	17,900	TDR&TXV	15.00		13.00	58MVB080–14
	CSPH*2412A**	18,000	TXV		14.00	11.50	
	FF1ENP018	17,800	TDR&TXV	13.50		11.20	
	FF1ENP024	18,000	TDR&TXV	13.50		11.20	
	FV4BNF002	18,200	TDR&TXV	15.00		13.20	
	FX4CNF018	18,000	TDR&TXV	15.00		13.00	
	FX4CNF024	18,300	TDR&TXV	15.00		13.00	
	FY4ANF018	17,800	TDR&TXV	13.50		11.20	
	FY4ANF024	17,900	TDR&TXV	13.50		11.20	
	CAP**2414A**	23,600	TXV		14.00	11.50	
	CAP**2414A**	23,200	TDR&TXV	15.00		12.50	58CV(A,X)070–12
	CAP**2417A**	23,600	TXV		14.00	11.50	
	CAP**2417A**	23,400	TDR&TXV	15.00		12.50	58MVB060–14
	CAP**2417A**	23,400	TDR&TXV	15.00		12.50	58UVB060–14
*CAP**3014A**	24,000	TXV		14.00	11.5		
CAP**3014A**	24,400	TDR&TXV	15.00		13.00	58CV(A,X)070–12	
CAP**3017A**	24,000	TXV		14.00	11.50		
CAP**3017A**	24,400	TDR&TXV	15.00		13.00	58MVB060–14	
CAP**3017A**	24,400	TDR&TXV	15.00		13.00	58UVB060–14	
CAP**3017A**	24,400	TDR&TXV	15.00		13.00	58CV(A,X)090–16	
CNPV*2414A**	23,600	TXV		14.00	11.50		
CNPV*2414A**	23,200	TDR&TXV	15.00		12.50	58CV(A,X)070–12	
CNPV*2417A**	23,600	TXV		14.00	11.50		
CNPV*2417A**	23,400	TDR&TXV	15.00		12.50	58MVB060–14	
CNPV*2417A**	23,400	TDR&TXV	15.00		12.50	58UVB060–14	
CNPV*2417A**	23,600	TDR&TXV	15.00		12.50	58CV(A,X)090–16	
CNPV*3014A**	24,000	TXV		14.00	11.50		
CNPV*3014A**	24,400	TDR&TXV	15.00		12.50	58CV(A,X)070–12	
CNPV*3017A**	24,000	TXV		14.00	11.50		
CNPV*3017A**	24,400	TDR&TXV	15.00		13.00	58MVB060–14	
CNPV*3017A**	24,400	TDR&TXV	15.00		13.00	58UVB060–14	

24ABA4

See notes on pg. 16

**COMBINATION RATINGS - CONTINUED**

Unit Size – Voltage, Series	Indoor Model	Total Cap. BTUH	Factory Supplied Enhancement	SEER		EER	Furnace Model
				Standard Rating	TDR†		
24-31	CNPV*3017A**	24,400	TDR&TXV	15.00		13.00	58CV(A,X)090-16
	CNPH*2417A**	23,600	TXV		14.00	11.50	
	CNPH*2417A**	23,400	TDR&TXV	15.00		12.50	58MVB040-14
	CNPH*2417A**	23,400	TDR&TXV	15.00		12.50	58CV(A,X)070-12
	CNPH*3017A**	24,000	TXV		14.00	11.50	
	CNPH*3017A**	24,400	TDR&TXV	15.00		13.00	58MVB040-14
	CNPH*3017A**	24,400	TDR&TXV	15.00		13.00	58CV(A,X)070-12
	CNPF*2418A**	23,600	TXV		14.00	11.50	
	CSPH*2412A**	23,600	TXV		14.00	11.50	
	CSPH*2412A**	23,200	TDR&TXV	15.00		12.50	58MVB040-14
	CSPH*2412A**	23,200	TDR&TXV	15.00		12.50	58CV(A,X)070-12
	CSPH*2412A**	23,200	TDR&TXV	15.00		13.00	58CV(A,X)110-20
	CSPH*2412A**	23,200	TDR&TXV	15.00		13.00	58CV(A,X)135-22
	CSPH*2412A**	23,200	TDR&TXV	15.00		13.00	58CV(A,X)155-22
	CSPH*3012A**	24,000	TXV		14.00	11.50	
	CSPH*3012A**	24,400	TDR&TXV	15.00		13.00	58MVB040-14
	CSPH*3012A**	24,400	TDR&TXV	15.00		13.00	58MVB060-14
	CSPH*3012A**	24,400	TDR&TXV	15.00		13.00	58MVB080-14
	CSPH*3012A**	24,400	TDR&TXV	15.00		13.00	58MVB080-20
	CSPH*3012A**	24,400	TDR&TXV	15.00		13.00	58MVB100-20
	CSPH*3012A**	24,400	TDR&TXV	15.00		13.00	58MVB120-20
	CSPH*3012A**	24,400	TDR&TXV	15.00		13.00	58CV(A,X)070-12
	CSPH*3012A**	24,400	TDR&TXV	15.00		13.00	58CV(A,X)090-16
	CSPH*3012A**	24,400	TDR&TXV	15.00		13.00	58CV(A,X)110-20
	CSPH*3012A**	24,400	TDR&TXV	15.00		13.00	58CV(A,X)135-22
	CSPH*3012A**	24,400	TDR&TXV	15.00		13.00	58CV(A,X)155-22
	FY4ANF024	23,400	TDR&TXV	13.50		11.20	
	FY4ANF030	23,600	TDR&TXV	14.00		11.50	
	FX4CNF024	23,800	TDR&TXV	15.00		12.50	
	FX4CNF030	24,000	TDR&TXV	15.00		13.00	
	FF1ENP024	23,400	TDR&TXV	13.50		11.20	
	FF1ENP030	23,400	TDR&TXV	13.50		11.20	
	FV4BNF002	23,800	TDR&TXV	15.00		13.00	
	FV4BNF003	23,800	TDR&TXV	15.00		13.20	
	*CAP**3014A**	29,000	TXV		14.00	12.00	
	CAP**3014A**	28,800	TDR&TXV	15.00		12.50	58CV(A,X)070-12
	CAP**3017A**	28,800	TDR&TXV	15.00		13.00	58CV(A,X)090-16
	CAP**3017A**	28,800	TDR&TXV	15.00		12.50	58MVB060-14
	CAP**3017A**	28,800	TDR&TXV	15.00		12.50	58UVB060-14
	CAP**3017A**	29,000	TXV		14.00	11.50	
	CAP**3614A**	27,800	TDR&TXV	15.00		12.50	58CV(A,X)070-12
	CAP**3614A**	28,200	TXV		14.00	11.50	
	CAP**3617A**	29,000	TDR&TXV	15.00		13.00	58CV(A,X)090-16
	CAP**3617A**	28,800	TDR&TXV	15.00		13.00	58MVB060-14
	CAP**3617A**	28,800	TDR&TXV	15.00		13.00	58UVB060-14
CAP**3617A**	29,200	TXV		14.00	11.50		
CAP**3621A**	29,000	TDR&TXV	15.00		13.00	58CV(A,X)110-20	
CAP**3621A**	29,000	TDR&TXV	15.00		12.50	58MVB080-14	
CAP**3621A**	29,000	TDR&TXV	15.00		12.50	58UVB080-14	
CAP**3621A**	29,200	TXV		14.00	11.50		
CNPF*3618A**	29,200	TXV		14.00	11.50		
CNPH*3017A**	28,800	TDR&TXV	15.00		12.50	58CV(A,X)070-12	
CNPH*3017A**	28,800	TDR&TXV	15.00		12.50	58MVB040-14	
CNPH*3017A**	28,800	TDR&TXV	15.00		12.50	58MVB120-20	
CNPH*3017A**	29,000	TXV		14.00	11.50		
CNPH*3617A**	28,800	TDR&TXV	15.00		12.50	58CV(A,X)070-12	
CNPH*3617A**	28,800	TDR&TXV	15.00		12.50	58MVB040-14	

24ABA4

See notes on pg. 16

**COMBINATION RATINGS - CONTINUED**

Unit Size – Voltage, Series	Indoor Model	Total Cap. BTUH	Factory Supplied Enhancement	SEER		EER	Furnace Model
				Standard Rating	TDR†		
30–31	CNPH*3617A**	29,200	TXV		14.00	11.50	
	CNPV*3014A**	28,800	TDR&TXV	15.00		12.50	58CV(A,X)070–12
	CNPV*3014A**	29,000	TXV		14.00	11.50	
	CNPV*3017A**	28,800	TDR&TXV	15.00		12.50	58CV(A,X)090–16
	CNPV*3017A**	28,800	TDR&TXV	15.00		12.50	58MVB060–14
	CNPV*3017A**	28,800	TDR&TXV	15.00		12.50	58UVB060–14
	CNPV*3017A**	29,000	TXV		14.00	11.50	
	CNPV*3617A**	29,000	TDR&TXV	15.00		12.50	58CV(A,X)090–16
	CNPV*3617A**	28,800	TDR&TXV	15.00		12.50	58MVB060–14
	CNPV*3617A**	28,800	TDR&TXV	15.00		12.50	58UVB060–14
	CNPV*3617A**	29,200	TXV		14.00	11.50	
	CNPV*3621A**	29,000	TDR&TXV	15.00		12.50	58CV(A,X)110–20
	CNPV*3621A**	29,000	TDR&TXV	15.00		12.50	58MVB080–14
	CNPV*3621A**	29,000	TDR&TXV	15.00		12.50	58UVB080–14
	CNPV*3621A**	29,200	TXV		14.00	11.50	
	CSPH*3012A**	28,800	TDR&TXV	15.00		12.50	58CV(A,X)070–12
	CSPH*3012A**	28,800	TDR&TXV	15.00		12.50	58MVB040–14
	CSPH*3012A**	29,000	TXV		14.00	11.50	
	CSPH*3612A**	28,800	TDR&TXV	15.00		13.00	58CV(A,X)070–12
	CSPH*3612A**	28,800	TDR&TXV	15.00		13.00	58MVB040–14
	CSPH*3612A**	29,200	TXV		14.00	11.50	
	FF1ENP030	28,600	TDR&TXV	14.00		11.50	
	FF1ENP036	29,200	TDR&TXV	14.00		11.50	
	FV4BNF002	29,000	TDR&TXV	15.00		12.50	
	FV4BNF003	29,200	TDR&TXV	15.00		13.00	
	FV4BNF005	30,000	TDR&TXV	15.00		13.20	
	FX4CN(B,F)036	29,600	TDR&TXV	15.00		12.50	
	FX4CNF030	29,200	TDR&TXV	15.00		12.50	
	FY4ANF030	28,800	TDR&TXV	14.00		11.50	
	FY4ANF036	29,000	TDR&TXV	14.00		11.50	
36–31	CAP**3614A**	35,000	TXV		14.00	11.50	
	CAP**3614A**	35,000	TDR&TXV	14.50		11.70	58CV(A,X)070–12
	CAP**3617A**	35,400	TXV		14.00	11.50	
	CAP**3617A**	35,000	TDR&TXV	15.00		12.00	58MVB060–14
	CAP**3617A**	35,000	TDR&TXV	15.00		12.00	58UVB060–14
	CAP**3617A**	35,000	TDR&TXV	15.00		12.00	58CV(A,X)090–16
	CAP**3621A**	35,400	TXV		14.00	11.50	
	CAP**3621A**	35,000	TDR&TXV	14.50		11.70	58MVB080–14
	CAP**3621A**	35,000	TDR&TXV	15.00		12.00	58MVB080–20
	CAP**3621A**	35,200	TDR&TXV	15.00		12.00	58MVB100–20
	CAP**3621A**	35,000	TDR&TXV	14.50		11.70	58UVB080–14
	CAP**3621A**	35,000	TDR&TXV	15.00		12.00	58UVB080–20
	CAP**3621A**	35,200	TDR&TXV	15.00		12.00	58UVB100–20
	CAP**3621A**	35,200	TDR&TXV	15.00		12.00	58CV(A,X)110–20
	*CAP**4221A**	35,800	TXV		14.00	11.5	
	CAP**4221A**	35,200	TDR&TXV	14.50		11.70	58MVB080–14
	CAP**4221A**	35,400	TDR&TXV	15.00		12.00	58MVB080–20
	CAP**4221A**	35,400	TDR&TXV	15.00		12.00	58MVB100–20
	CAP**4221A**	35,200	TDR&TXV	14.50		11.70	58UVB080–14
	CAP**4221A**	35,400	TDR&TXV	15.00		12.00	58UVB080–20
	CAP**4221A**	35,400	TDR&TXV	15.00		12.00	58UVB100–20
	CAP**4221A**	35,400	TDR&TXV	15.00		12.00	58CV(A,X)110–20
	CAP**4224A**	35,800	TXV		14.00	11.50	
	CAP**4224A**	35,200	TDR&TXV	15.00		12.00	58MVB040–14
	CAP**4224A**	35,400	TDR&TXV	15.00		12.00	58MVB120–20
	CAP**4224A**	35,400	TDR&TXV	15.00		12.00	58UVB120–20
	CAP**4224A**	35,400	TDR&TXV	15.00		12.00	58CV(A,X)135–22
	CNPV*3617A**	35,400	TXV		14.00	11.50	
	CNPV*3617A**	35,000	TDR&TXV	14.50		11.70	58MVB060–14
	CNPV*3617A**	35,000	TDR&TXV	14.50		11.70	58UVB060–14
CNPV*3617A**	35,000	TDR&TXV	15.00		12.00	58CV(A,X)090–16	
CNPV*3621A**	35,400	TXV		14.00	11.50		
CNPV*3621A**	34,800	TDR&TXV	14.50		11.70	58MVB080–14	
CNPV*3621A**	34,800	TDR&TXV	14.50		11.70	58UVB080–14	
CNPV*3621A**	35,000	TDR&TXV	15.00		12.00	58CV(A,X)110–20	

24ABA4

See notes on pg. 16

**COMBINATION RATINGS - CONTINUED**

Unit Size – Voltage, Series	Indoor Model	Total Cap. BTUH	Factory Supplied Enhancement	SEER		EER	Furnace Model
				Standard Rating	TDR†		
36–31	CNPV*4221A**	35,800	TXV		14.00	11.50	
	CNPV*4221A**	35,400	TDR&TXV	15.00		12.00	58MVB080–14
	CNPV*4221A**	35,400	TDR&TXV	15.00		12.00	58UVB080–14
	CNPV*4221A**	35,600	TDR&TXV	15.00		13.00	58CV(A,X)110–20
	CNPH*3617A**	35,400	TXV		14.00	11.50	
	CNPH*3617A**	34,800	TDR&TXV	14.50		11.70	58MVB040–14
	CNPH*3617A**	35,000	TDR&TXV	14.50		11.70	58CV(A,X)070–12
	CNPH*4221A**	35,800	TXV		14.00	11.50	
	CNPH*4221A**	35,400	TDR&TXV	15.00		12.00	58MVB040–14
	CNPH*4221A**	35,400	TDR&TXV	15.00		12.00	58CV(A,X)070–12
	CNPH*4221A**	35,600	TDR&TXV	15.00		13.00	58CV(A,X)135–22
	CNPH*4221A**	35,600	TDR&TXV	15.00		13.00	58CV(A,X)155–22
	CNPF*3618A**	35,400	TXV		14.00	11.50	
	CSPH*3612A**	36,200	TXV		14.00	11.50	
	CSPH*3612A**	35,600	TDR&TXV	15.00		12.00	58MVB040–14
	CSPH*3612A**	35,800	TDR&TXV	15.00		12.00	58CV(A,X)070–12
	CSPH*4212A**	36,600	TXV		14.00	11.50	
	CSPH*4212A**	35,800	TDR&TXV	15.00		12.00	58MVB040–14
	CSPH*4212A**	36,000	TDR&TXV	15.00		12.00	58MVB120–20
	CSPH*4212A**	36,000	TDR&TXV	15.00		12.00	58CV(A,X)070–12
	FY4ANF036	34,800	TDR&TXV	14.00		11.50	
	FY4ANF042	36,000	TDR&TXV	14.00		11.50	
	FX4CN(B,F)036	36,000	TDR&TXV	15.00		12.00	
	FX4CN(B,F)042	36,600	TDR&TXV	15.00		12.00	
	FF1ENP036	35,000	TDR&TXV	14.00		11.50	
	FV4BNF002	35,200	TDR&TXV	15.00		12.00	
	FV4BNF003	35,400	TDR&TXV	15.00		12.00	
	FV4BNF005	36,600	TDR&TXV	15.00		13.00	
	*CAP**4821A**	40,500	TXV		14.00	12.00	
	CAP**4221A**	39,500	TDR&TXV	14.50		12.20	58CV(A,X)110–20
	CAP**4221A**	39,000	TDR&TXV	14.00		12.00	58MVB080–14
	CAP**4221A**	39,500	TDR&TXV	14.50		12.20	58MVB080–20
	CAP**4221A**	39,500	TDR&TXV	14.50		12.20	58MVB100–20
	CAP**4221A**	39,000	TDR&TXV	14.00		12.00	58UVB080–14
	CAP**4221A**	39,500	TDR&TXV	14.50		12.20	58UVB080–20
	CAP**4221A**	39,500	TDR&TXV	14.50		12.20	58UVB100–20
CAP**4221A**	40,000	TXV		13.50	11.70		
CAP**4224A**	39,500	TDR&TXV	15.00		12.50	58CV(A,X)135–22	
CAP**4224A**	39,500	TDR&TXV	15.00		12.50	58CV(A,X)155–22	
CAP**4224A**	39,000	TDR&TXV	14.50		12.20	58MVB040–14	
CAP**4224A**	39,500	TDR&TXV	14.50		12.20	58MVB120–20	
CAP**4224A**	39,500	TDR&TXV	14.50		12.20	58UVB120–20	
CAP**4224A**	40,000	TXV		13.50	11.70		
CAP**4817A**	39,500	TDR&TXV	15.00		12.50	58CV(A,X)090–16	
CAP**4817A**	39,000	TDR&TXV	14.50		12.20	58MVB060–14	
CAP**4817A**	39,000	TDR&TXV	14.50		12.20	58UVB060–14	
CAP**4817A**	39,500	TXV		14.00	12.00		
CAP**4821A**	40,000	TDR&TXV	15.00		12.50	58CV(A,X)110–20	
CAP**4821A**	40,000	TDR&TXV	14.50		12.20	58MVB080–14	
CAP**4821A**	40,000	TDR&TXV	14.50		12.20	58MVB080–20	
CAP**4821A**	40,000	TDR&TXV	15.00		12.50	58MVB100–20	
CAP**4821A**	40,000	TDR&TXV	14.50		12.20	58UVB080–14	
CAP**4821A**	40,000	TDR&TXV	14.50		12.20	58UVB080–20	
CAP**4821A**	40,000	TDR&TXV	15.00		12.50	58UVB100–20	
CAP**4824A**	40,000	TDR&TXV	15.00		12.50	58CV(A,X)135–22	
CAP**4824A**	40,000	TDR&TXV	15.00		12.50	58CV(A,X)155–22	
CAP**4824A**	40,000	TDR&TXV	14.50		12.20	58MVB040–14	
CAP**4824A**	40,000	TDR&TXV	15.00		12.50	58MVB120–20	
CAP**4824A**	40,000	TDR&TXV	15.00		12.50	58UVB120–20	
CAP**4824A**	40,500	TXV		14.00	12.00		

See notes on pg. 16

24ABA4

**COMBINATION RATINGS - CONTINUED**

Unit Size – Voltage, Series	Indoor Model	Total Cap. BTUH	Factory Supplied Enhancement	SEER		EER	Furnace Model
				Standard Rating	TDR†		
42–32	CNPF*4818A**	39,500	TXV		14.00	11.50	
	CNPH*4221A**	39,500	TDR&TXV	14.00		12.00	58CV(A,X)070–12
	CNPH*4221A**	39,500	TDR&TXV	14.50		12.20	58CV(A,X)090–16
	CNPH*4221A**	39,500	TDR&TXV	14.50		12.20	58CV(A,X)110–20
	CNPH*4221A**	39,500	TDR&TXV	15.00		12.50	58CV(A,X)135–22
	CNPH*4221A**	39,500	TDR&TXV	15.00		12.50	58CV(A,X)155–22
	CNPH*4221A**	39,500	TDR&TXV	14.00		12.00	58MVB040–14
	CNPH*4221A**	39,500	TDR&TXV	14.50		12.20	58MVB060–14
	CNPH*4221A**	39,000	TDR&TXV	14.00		12.00	58MVB080–14
	CNPH*4221A**	39,500	TDR&TXV	14.50		12.20	58MVB080–20
	CNPH*4221A**	39,500	TDR&TXV	14.50		12.20	58MVB100–20
	CNPH*4221A**	39,500	TDR&TXV	14.50		12.20	58MVB120–20
	CNPH*4221A**	40,000	TXV		13.50	11.70	
	CNPH*4821A**	40,000	TDR&TXV	14.50		12.20	58CV(A,X)070–12
	CNPH*4821A**	40,000	TDR&TXV	15.00		12.50	58CV(A,X)090–16
	CNPH*4821A**	40,500	TDR&TXV	15.00		12.50	58CV(A,X)110–20
	CNPH*4821A**	40,500	TDR&TXV	15.00		12.50	58CV(A,X)135–22
	CNPH*4821A**	40,500	TDR&TXV	15.00		12.50	58CV(A,X)155–22
	CNPH*4821A**	40,000	TDR&TXV	14.50		12.20	58MVB040–14
	CNPH*4821A**	40,000	TDR&TXV	15.00		12.50	58MVB060–14
	CNPH*4821A**	40,000	TDR&TXV	14.50		12.20	58MVB080–14
	CNPH*4821A**	40,000	TDR&TXV	14.50		12.20	58MVB080–20
	CNPH*4821A**	40,000	TDR&TXV	15.00		12.50	58MVB100–20
	CNPH*4821A**	40,000	TDR&TXV	15.00		12.50	58MVB120–20
	CNPH*4821A**	40,500	TXV		14.00	12.00	
	CNPV*4221A**	39,500	TDR&TXV	14.50		12.20	58CV(A,X)110–20
	CNPV*4221A**	39,000	TDR&TXV	14.00		12.00	58MVB080–14
	CNPV*4221A**	39,500	TDR&TXV	14.50		12.20	58MVB080–20
	CNPV*4221A**	39,500	TDR&TXV	14.50		12.20	58MVB100–20
	CNPV*4221A**	39,000	TDR&TXV	14.00		12.00	58UVB080–14
	CNPV*4221A**	39,500	TDR&TXV	14.50		12.20	58UVB080–20
	CNPV*4221A**	39,500	TDR&TXV	14.50		12.20	58UVB100–20
	CNPV*4221A**	40,000	TXV		13.50	11.70	
	CNPV*4821A**	40,500	TDR&TXV	15.00		12.50	58CV(A,X)110–20
	CNPV*4821A**	40,000	TDR&TXV	14.50		12.20	58MVB080–14
	CNPV*4821A**	40,000	TDR&TXV	14.50		12.20	58MVB080–20
	CNPV*4821A**	40,000	TDR&TXV	15.00		12.50	58MVB100–20
	CNPV*4821A**	40,000	TDR&TXV	14.50		12.20	58UVB080–14
	CNPV*4821A**	40,000	TDR&TXV	14.50		12.20	58UVB080–20
	CNPV*4821A**	40,000	TDR&TXV	15.00		12.50	58UVB100–20
	CNPV*4821A**	40,500	TXV		14.00	12.00	
	CNPV*4824A**	40,500	TDR&TXV	15.00		12.50	58CV(A,X)135–22
	CNPV*4824A**	40,500	TDR&TXV	15.00		12.50	58CV(A,X)155–22
	CNPV*4824A**	40,000	TDR&TXV	14.50		12.20	58MVB040–14
	CNPV*4824A**	40,000	TDR&TXV	15.00		12.50	58MVB120–20
	CNPV*4824A**	40,000	TDR&TXV	15.00		12.50	58UVB120–20
	CNPV*4824A**	40,500	TXV		14.00	12.00	
	CSPH*4212A**	39,500	TDR&TXV	14.50		12.20	58CV(A,X)070–12
	CSPH*4212A**	40,000	TDR&TXV	14.50		12.20	58CV(A,X)090–16
	CSPH*4212A**	40,000	TDR&TXV	14.50		12.20	58CV(A,X)110–20
	CSPH*4212A**	40,000	TDR&TXV	15.00		12.50	58CV(A,X)135–22
	CSPH*4212A**	40,000	TDR&TXV	15.00		12.50	58CV(A,X)155–22
CSPH*4212A**	39,500	TDR&TXV	14.00		12.20	58MVB040–14	
CSPH*4212A**	39,500	TDR&TXV	14.50		12.20	58MVB060–14	
CSPH*4212A**	39,500	TDR&TXV	14.50		12.20	58MVB080–14	
CSPH*4212A**	39,500	TDR&TXV	14.50		12.20	58MVB080–20	
CSPH*4212A**	40,000	TDR&TXV	14.50		12.20	58MVB100–20	
CSPH*4212A**	39,500	TDR&TXV	15.00		12.20	58MVB120–20	
CSPH*4212A**	40,000	TXV		13.50	11.70		
CSPH*4812A**	40,500	TDR&TXV	14.50		12.20	58CV(A,X)070–12	
CSPH*4812A**	40,500	TDR&TXV	15.00		12.50	58CV(A,X)090–16	
CSPH*4812A**	40,500	TDR&TXV	15.00		12.50	58CV(A,X)110–20	

24ABA4

See notes on pg. 16

**COMBINATION RATINGS - CONTINUED**

Unit Size – Voltage, Series	Indoor Model	Total Cap. BTUH	Factory Supplied Enhancement	SEER		EER	Furnace Model
				Standard Rating	TDR†		
42–32	CSPH*4812A**	40,500	TDR&TXV	15.00		12.50	58CV(A,X)135–22
	CSPH*4812A**	40,500	TDR&TXV	15.00		12.50	58CV(A,X)155–22
	CSPH*4812A**	40,000	TDR&TXV	14.50		12.20	58MVB040–14
	CSPH*4812A**	40,500	TDR&TXV	14.50		12.20	58MVB060–14
	CSPH*4812A**	40,000	TDR&TXV	14.50		12.20	58MVB080–14
	CSPH*4812A**	40,500	TDR&TXV	14.50		12.20	58MVB080–20
	CSPH*4812A**	40,500	TDR&TXV	15.00		12.50	58MVB100–20
	CSPH*4812A**	40,500	TDR&TXV	15.00		12.50	58MVB120–20
	CSPH*4812A**	40,500	TXV		14.00	12.00	
	FE4AN(B,F)003	39,500	TDR&TXV	15.00		12.50	
	FE4AN(B,F)005	41,000	TDR&TXV	15.50		13.00	
	FE4ANB006	41,500	TDR&TXV	15.50		13.00	
	FE5ANB004	41,500	TDR&TXV	15.50		13.00	
	FV4BN(B,F)003	39,500	TDR&TXV	15.00		12.50	
	FV4BN(B,F)005	41,000	TDR&TXV	15.50		13.00	
	FV4BNB006	41,500	TDR&TXV	15.50		13.00	
	FX4CN(B,F)042	40,500	TDR&TXV	14.50		12.20	
	FX4CN(B,F)048	41,500	TDR&TXV	15.00		12.50	
FY4ANF042	40,000	TDR&TXV	13.50		11.70		
FY4ANF048	41,000	TDR&TXV	14.00		12.00		
*CAP**6024A**	48,000	TXV		14.00	11.7		
CAP**4817A**	46,500	TDR&TXV	14.00		12.00	58CV(A,X)090–16	
CAP**4817A**	46,500	TXV		13.50	11.70		
CAP**4821A**	46,500	TDR&TXV	14.50		12.00	58CV(A,X)110–20	
CAP**4821A**	46,500	TDR&TXV	14.00		11.70	58MVB080–20	
CAP**4821A**	46,500	TDR&TXV	14.00		12.00	58MVB100–20	
CAP**4821A**	46,500	TDR&TXV	14.00		11.70	58UVB080–20	
CAP**4821A**	46,500	TDR&TXV	14.00		12.00	58UVB100–20	
CAP**4821A**	47,500	TXV		13.50	11.50		
CAP**4824A**	47,000	TDR&TXV	14.50		12.20	58CV(A,X)135–22	
CAP**4824A**	47,000	TDR&TXV	14.50		12.20	58CV(A,X)155–22	
CAP**4824A**	46,500	TDR&TXV	14.00		12.00	58MVB120–20	
CAP**4824A**	46,500	TDR&TXV	14.00		12.00	58UVB120–20	
CAP**4824A**	47,500	TXV		13.50	11.50		
CAP**6021A**	47,500	TDR&TXV	15.00		12.50	58CV(A,X)110–20	
CAP**6021A**	47,500	TDR&TXV	14.50		12.20	58MVB080–20	
CAP**6021A**	47,500	TDR&TXV	14.50		12.20	58MVB100–20	
CAP**6021A**	47,500	TDR&TXV	14.50		12.20	58UVB080–20	
CAP**6021A**	47,500	TDR&TXV	14.50		12.20	58UVB100–20	
CAP**6021A**	48,000	TXV		14.00	11.70		
CAP**6024A**	48,000	TDR&TXV	15.00		12.50	58CV(A,X)135–22	
CAP**6024A**	48,000	TDR&TXV	15.00		12.50	58CV(A,X)155–22	
CAP**6024A**	47,500	TDR&TXV	14.50		12.20	58MVB120–20	
CAP**6024A**	47,500	TDR&TXV	14.50		12.20	58UVB120–20	
CNPF*4818A**	46,500	TXV		13.50	11.50		
CNPH*4821A**	47,000	TDR&TXV	14.50		12.00	58CV(A,X)090–16	
CNPH*4821A**	4,700	TDR&TXV	14.50		12.20	58CV(A,X)110–20	
CNPH*4821A**	47,000	TDR&TXV	14.50		12.20	58CV(A,X)135–22	
CNPH*4821A**	47,000	TDR&TXV	15.00		12.50	58CV(A,X)155–22	
CNPH*4821A**	46,500	TDR&TXV	14.00		12.00	58MVB080–20	
CNPH*4821A**	46,500	TDR&TXV	14.00		12.00	58MVB100–20	
CNPH*4821A**	46,500	TDR&TXV	14.50		12.00	58MVB120–20	
CNPH*4821A**	47,500	TXV		13.50	11.50		
CNPH*6024A**	47,500	TDR&TXV	14.50		12.20	58CV(A,X)090–16	
CNPH*6024A**	47,500	TDR&TXV	14.50		12.20	58CV(A,X)110–20	
CNPH*6024A**	48,000	TDR&TXV	15.00		12.50	58CV(A,X)135–22	
CNPH*6024A**	48,000	TDR&TXV	15.00		12.50	58CV(A,X)155–22	
CNPH*6024A**	47,500	TDR&TXV	14.50		12.20	58MVB080–20	
CNPH*6024A**	47,500	TDR&TXV	14.50		12.20	58MVB100–20	
CNPH*6024A**	47,500	TDR&TXV	14.50		12.20	58MVB120–20	
CNPH*6024A**	48,000	TXV		14.00	11.70		

24ABA4

See notes on pg. 16

**COMBINATION RATINGS - CONTINUED**

Unit Size – Voltage, Series	Indoor Model	Total Cap. BTUH	Factory Supplied Enhancement	SEER		EER	Furnace Model
				Standard Rating	TDR†		
48-32	CNPV*4821A**	47,000	TDR&TXV	14.50		12.20	58CV(A,X)110-20
	CNPV*4821A**	46,500	TDR&TXV	14.00		12.00	58MVB080-20
	CNPV*4821A**	46,500	TDR&TXV	14.00		12.00	58MVB100-20
	CNPV*4821A**	46,500	TDR&TXV	14.00		12.00	58UVB080-20
	CNPV*4821A**	46,500	TDR&TXV	14.00		12.00	58UVB100-20
	CNPV*4821A**	47,500	TXV		13.50	11.50	
	CNPV*4824A**	4,700	TDR&TXV	14.50		12.20	58CV(A,X)135-22
	CNPV*4824A**	47,000	TDR&TXV	15.00		12.50	58CV(A,X)155-22
	CNPV*4824A**	46,500	TDR&TXV	14.50		12.00	58MVB120-20
	CNPV*4824A**	46,500	TDR&TXV	14.50		12.00	58UVB120-20
	CNPV*4824A**	47,500	TXV		13.50	11.50	
	CNPV*6024A**	48,000	TDR&TXV	15.00		12.50	58CV(A,X)135-22
	CNPV*6024A**	48,000	TDR&TXV	15.00		12.50	58CV(A,X)155-22
	CNPV*6024A**	47,500	TDR&TXV	14.50		12.20	58MVB120-20
	CNPV*6024A**	47,500	TDR&TXV	14.50		12.20	58UVB120-20
	CNPV*6024A**	48,000	TXV		14.00	11.70	
	CSPH*4812A**	47,000	TDR&TXV	14.50		12.00	58CV(A,X)090-16
	CSPH*4812A**	47,000	TDR&TXV	14.50		12.20	58CV(A,X)110-20
	CSPH*4812A**	47,500	TDR&TXV	14.50		12.20	58CV(A,X)135-22
	CSPH*4812A**	47,000	TDR&TXV	14.50		12.20	58CV(A,X)155-22
	CSPH*4812A**	46,500	TDR&TXV	14.00		11.70	58MVB080-20
	CSPH*4812A**	46,500	TDR&TXV	14.00		12.00	58MVB100-20
	CSPH*4812A**	47,000	TDR&TXV	14.50		12.00	58MVB120-20
	CSPH*4812A**	47,500	TXV		13.50	11.70	
	CSPH*6012A**	48,000	TDR&TXV	14.50		12.20	58CV(A,X)090-16
	CSPH*6012A**	48,000	TDR&TXV	15.00		12.50	58CV(A,X)110-20
	CSPH*6012A**	48,000	TDR&TXV	15.00		12.50	58CV(A,X)135-22
	CSPH*6012A**	48,000	TDR&TXV	15.00		12.50	58CV(A,X)155-22
	CSPH*6012A**	47,500	TDR&TXV	14.50		12.20	58MVB080-20
	CSPH*6012A**	48,000	TDR&TXV	14.50		12.20	58MVB100-20
	CSPH*6012A**	48,000	TDR&TXV	14.50		12.20	58MVB120-20
	CSPH*6012A**	48,000	TXV		14.00	11.70	
	FE4AN(B,F)005	48,000	TDR&TXV	15.00		12.50	
	FE4ANB006	48,000	TDR&TXV	15.50		13.00	
	FV4BN(B,F)005	48,000	TDR&TXV	15.00		12.50	
	FV4BNB006	48,000	TDR&TXV	15.50		13.00	
	FX4CN(B,F)048	48,000	TDR&TXV	14.50		12.20	
	FX4CN(B,F)060	49,000	TDR&TXV	15.00		12.50	
	FY4ANB060	48,000	TDR&TXV	14.00		11.70	
	FY4ANF048	48,000	TDR&TXV	13.50		11.50	
	*CAP**6024A**	59,000	TXV		14.00	12.00	
	CAP**6021A**	56,000	TDR&TXV	14.20		12.00	58MVB080-20
	CAP**6021A**	56,000	TDR&TXV	14.50		12.20	58MVB100-20
	CAP**6021A**	56,000	TDR&TXV	14.20		12.00	58UVB080-20
	CAP**6021A**	56,000	TDR&TXV	14.50		12.20	58UVB100-20
	CAP**6021A**	58,000	TXV		14.00	12.00	
	CAP**6024A**	58,000	TDR&TXV	14.20		12.00	58CV(A,X)135-22
	CAP**6024A**	58,000	TDR&TXV	14.50		12.20	58CV(A,X)155-22
CAP**6024A**	55,500	TDR&TXV	14.50		12.20	58MVB120-20	
CAP**6024A**	55,500	TDR&TXV	14.50		12.20	58UVB120-20	
CNPH*6024A**	58,000	TDR&TXV	14.20		12.00	58CV(A,X)110-20	
CNPH*6024A**	58,000	TDR&TXV	14.50		12.20	58CV(A,X)135-22	
CNPH*6024A**	58,000	TDR&TXV	14.50		12.20	58CV(A,X)155-22	
CNPH*6024A**	55,500	TDR&TXV	14.20		12.00	58MVB080-20	
CNPH*6024A**	56,000	TDR&TXV	14.50		12.20	58MVB100-20	
CNPH*6024A**	55,500	TDR&TXV	14.50		12.20	58MVB120-20	
CNPH*6024A**	59,000	TXV		14.00	12.00		
CNPV*6024A**	58,000	TDR&TXV	14.50		12.20	58CV(A,X)135-22	
CNPV*6024A**	58,000	TDR&TXV	14.50		12.20	58CV(A,X)155-22	
CNPV*6024A**	55,500	TDR&TXV	14.50		12.20	58MVB120-20	
CNPV*6024A**	55,500	TDR&TXV	14.50		12.20	58UVB120-20	

24ABA4

See notes on pg. 16

## COMBINATION RATINGS - CONTINUED

Unit Size – Voltage, Series	Indoor Model	Total Cap. BTUH	Factory Supplied Enhancement	SEER		EER	Furnace Model
				Standard Rating	TDR†		
60–32	CNPV*6024A**	59,000	TXV		14.00	12.00	
	CSPH*6012A**	58,000	TDR&TXV	14.20		12.00	58CV(A,X)110–20
	CSPH*6012A**	58,500	TDR&TXV	14.50		12.20	58CV(A,X)135–22
	CSPH*6012A**	58,500	TDR&TXV	14.50		12.20	58CV(A,X)155–22
	CSPH*6012A**	55,500	TDR&TXV	14.20		12.00	58MVB080–20
	CSPH*6012A**	55,500	TDR&TXV	14.50		12.20	58MVB100–20
	CSPH*6012A**	55,500	TDR&TXV	14.50		12.20	58MVB120–20
					14.00	12.00	
	FE4ANB006	59,000	TDR&TXV	14.50		12.20	
	FV4BNB006	59,000	TDR&TXV	14.50		12.20	
	FX4CN(B,F)060	60,000	TDR&TXV	14.50		12.20	
	FY4ANB060	59,000	TDR&TXV	13.50		11.50	

\* Tested combination

† In most cases, only 1 method should be used to achieve TDR function. Using more than 1 method in a system may cause degradation in performance. Use either the accessory Time–Delay Relay KAATD0101TDR or a furnace equipped with TDR. Most Carrier furnaces are equipped with TDR.

EER — Energy Efficiency Ratio

SEER — Seasonal Energy Efficiency Ratio

TDR — Time–Delay Relay

TXV — Thermostatic Expansion Valve

**NOTES:**

1. Ratings are net values reflecting the effects of circulating fan motor heat. Supplemental electric heat is not included.
2. Tested outdoor/indoor combinations have been tested in accordance with DOE test procedures for central air conditioners. Ratings for other combinations are determined under DOE computer simulation procedures.
3. Determine actual CFM values obtainable for your system by referring to fan performance data in fan coil or furnace coil literature.
4. Do not apply with capillary tube coils as performance and reliability are significantly affected.

24ABA4

# DETAILED COOLING CAPACITIES#

EVAPORATOR AIR		CONDENSER ENTERING AIR TEMPERATURES deg ° F (° C)																	
CFM	EWB	75 (23.9)			85 (29.4)			95 (35)			105 (40.6)			115 (46.1)			125 (51.7)		
		Capacity MBtuht	Total System KW**	Sens†	Capacity MBtuht	Total System KW**	Sens†	Capacity MBtuht	Total System KW**	Sens†	Capacity MBtuht	Total System KW**	Sens†	Capacity MBtuht	Total System KW**	Sens†	Capacity MBtuht	Total System KW**	Sens†
<b>24ABA418A31 Outdoor Section With CAP**2414A** Indoor Section</b>																			
	72	21.57	11.21	1.17	20.52	10.80	1.32	19.45	10.39	1.49	18.33	9.97	1.67	17.18	9.55	1.88	15.93	9.09	2.11
525	67	19.60	13.63	1.18	18.65	13.23	1.33	17.67	12.81	1.50	16.65	12.40	1.69	15.60	11.96	1.90	14.46	11.51	2.13
	62	17.82	16.04	1.19	16.96	15.63	1.34	16.08	15.22	1.51	15.18	14.79	1.70	14.29	14.29	1.91	13.44	13.44	2.13
	57	17.16	17.16	1.20	16.49	16.49	1.35	15.79	15.79	1.51	15.06	15.06	1.70	14.29	14.29	1.91	13.44	13.44	2.13
600	72	22.01	11.78	1.19	20.92	11.37	1.34	19.79	10.95	1.51	18.62	10.52	1.70	17.42	10.09	1.91	16.12	9.62	2.14
	67	20.03	14.54	1.21	19.03	14.13	1.36	18.00	13.71	1.53	16.94	13.28	1.71	15.84	12.84	1.92	14.66	12.37	2.15
	62	18.27	17.29	1.22	17.38	16.86	1.37	16.50	16.41	1.54	15.70	15.70	1.72	14.86	14.86	1.93	13.95	13.95	2.16
675	57	17.96	17.96	1.22	17.23	17.23	1.37	16.48	16.48	1.54	15.70	15.70	1.72	14.87	14.87	1.93	13.95	13.95	2.16
	72	22.34	12.32	1.22	21.20	11.90	1.37	20.03	11.47	1.54	18.83	11.04	1.72	17.58	10.60	1.93	16.24	10.13	2.16
	67	20.35	15.42	1.23	19.31	15.00	1.38	18.25	14.57	1.55	17.15	14.13	1.74	16.02	13.68	1.95	14.80	13.21	2.18
	62	18.68	18.46	1.24	17.86	17.86	1.39	17.06	17.06	1.56	16.22	16.22	1.75	15.33	15.33	1.95	14.37	14.37	2.18
	57	18.63	18.63	1.24	17.86	17.86	1.39	17.06	17.06	1.56	16.22	16.22	1.75	15.33	15.33	1.95	14.37	14.37	2.18

Cooling Indoor Model	Capacity	Power	Furnace Model
CNPV*2417A**	0.99	0.88	58MVB040-14
CSPH*2412A**	0.99	0.88	58MVB040-14
CAP**2417A**	0.99	0.88	58MVB060-14
CNPV*2417A**	0.99	0.88	58MVB060-14
CSPH*2412A**	0.99	0.88	58MVB060-14
CNPV*2417A**	0.99	0.88	58MVB060-14
CSPH*2412A**	0.99	0.88	58MVB060-14
CNPV*2417A**	0.99	0.88	58MVB060-14
CSPH*2412A**	0.99	0.88	58MVB060-14
CNPV*2417A**	0.99	0.88	58MVB060-14
CSPH*2412A**	0.99	0.88	58MVB060-14

See notes on pg. 23

Cooling Indoor Model	Capacity	Power	Furnace Model
*CAP**1814A**	1.00	1.00	
CAP**1814A**	0.99	1.02	
CAP**2417A**	1.00	1.00	
CNPF*2418A**	1.00	1.03	
CNPV*2417A**	1.00	1.03	
CNPV**1814A**	0.99	1.02	
CNPV*2414A**	1.00	1.00	
CNPV*2417A**	1.00	1.03	
CSPH*2412A**	1.00	1.00	
FF1ENP018	0.99	1.02	
FF1ENP024	1.00	1.03	
FV4BNF002	1.01	0.88	
FX4CNF018	1.00	0.88	
FX4CNF024	1.02	0.90	
FY4ANF018	0.99	1.02	
FY4ANF024	0.99	1.02	
CAP**1814A**	0.98	0.90	58CV(A.X)070-12
CAP**2414A**	0.99	0.88	58CV(A.X)070-12
CNPV*2417A**	0.99	0.88	58CV(A.X)070-12
CNPV**1814A**	0.98	0.90	58CV(A.X)070-12
CNPV*2414A**	0.99	0.88	58CV(A.X)070-12
CSPH*2412A**	0.99	0.88	58CV(A.X)070-12
CAP**2417A**	0.99	0.88	58CV(A.X)090-16
CNPV*2417A**	0.99	0.88	58CV(A.X)090-16
CSPH*2412A**	0.99	0.88	58CV(A.X)090-16

24ABA4

**DETAILED COOLING CAPACITIES# (CONT.)**

EVAPORATOR AIR		CONDENSER ENTERING AIR TEMPERATURES deg °F (°C)																	
CFM	EWB	75 (23.9)			85 (29.4)			95 (35)			105 (40.6)			115 (46.1)			125 (51.7)		
		Capacity MBtuht	Sens†	Total System KW**	Capacity MBtuht	Sens†	Total System KW**	Capacity MBtuht	Sens†	Total System KW**	Capacity MBtuht	Sens†	Total System KW**	Capacity MBtuht	Sens†	Total System KW**	Capacity MBtuht	Sens†	Total System KW**
<b>24ABA424A31 Outdoor Section With CAP**3014A** Indoor Section</b>																			
	72	28.59	14.92	1.54	27.34	14.44	1.73	26.02	13.94	1.95	24.62	13.41	2.19	23.11	12.85	2.45	21.45	12.25	2.74
<b>700</b>	67	25.94	18.18	1.55	24.78	17.69	1.74	23.56	17.18	1.96	22.27	16.64	2.19	20.88	16.08	2.46	19.35	15.46	2.75
	62	23.61	21.43	1.55	22.55	20.93	1.75	21.45	20.41	1.96	20.30	19.86	2.20	19.15	19.15	2.46	18.01	18.01	2.75
	57	22.84	22.84	1.56	22.01	22.01	1.75	21.12	21.12	1.96	20.18	20.18	2.20	19.15	19.15	2.46	18.01	18.01	2.75
	72	29.18	15.68	1.58	27.87	15.19	1.77	26.49	14.68	1.98	25.03	14.15	2.22	23.46	13.58	2.48	21.74	12.96	2.77
<b>800</b>	67	26.48	19.38	1.58	25.27	18.88	1.78	24.00	18.36	1.99	22.66	17.82	2.23	21.22	17.24	2.49	19.64	16.61	2.78
	62	24.19	23.07	1.59	23.12	22.54	1.78	22.00	22.00	2.00	21.01	21.01	2.23	19.91	19.91	2.50	18.69	18.69	2.78
	57	23.86	23.86	1.59	22.97	22.97	1.78	22.02	22.02	2.00	21.01	21.01	2.23	19.91	19.91	2.50	18.69	18.69	2.78
	72	29.62	16.40	1.61	28.26	15.90	1.80	26.84	15.38	2.02	25.33	14.84	2.26	23.71	14.26	2.52	21.93	13.64	2.81
<b>900</b>	67	26.89	20.53	1.62	25.64	20.02	1.81	24.33	19.50	2.03	22.95	18.94	2.27	21.46	18.35	2.53	19.85	17.71	2.82
	62	24.74	24.57	1.62	23.77	23.77	1.82	22.77	22.77	2.03	21.70	21.70	2.27	20.54	20.54	2.53	19.25	19.25	2.82
	57	24.71	24.71	1.62	23.77	23.77	1.82	22.77	22.77	2.03	21.70	21.70	2.27	20.54	20.54	2.53	19.25	19.25	2.82

Cooling Indoor Model	Capacity	Power	Furnace Model	Cooling Indoor Model	Capacity	Power	Furnace Model
CAP**2414A**	0.98	0.90	58CV(A.X)090-16	CSPH*3012A**	0.97	0.86	58CV(A.X)110-20
CAP**2417A**	1.00	0.98	58CV(A.X)110-20	CSPH*3012A**	1.02	0.90	58CV(A.X)110-20
CAP**3017A**	1.00	0.98	58CV(A.X)135-22	CSPH*3012A**	0.97	0.86	58CV(A.X)135-22
CNPV*2418A**	0.98	0.98	58CV(A.X)135-22	CSPH*3012A**	1.02	0.90	58CV(A.X)155-22
CNPV*2417A**	0.98	0.98	58CV(A.X)155-22	CSPH*3012A**	0.97	0.86	58CV(A.X)155-22
CNPV*3017A**	1.00	0.98	58CV(A.X)155-22	CNPV*2417A**	1.02	0.90	58MV040-14
CNPV*2414A**	0.98	0.98	58MV040-14	CNPV*2417A**	0.98	0.90	58MV040-14
CNPV*3014A**	1.00	1.00	58MV040-14	CNPV*3017A**	1.02	0.90	58MV060-14
CNPV*3017A**	1.00	1.00	58MV060-14	CSPH*2412A**	0.97	0.89	58MV060-14
CSPH*2412A**	0.98	0.98	58MV060-14	CSPH*3012A**	1.02	0.90	58MV080-14
CSPH*3012A**	0.98	0.98	58MV080-14	CAP**2417A**	1.02	0.90	58MV080-20
FF1ENP024	0.98	1.00	58MV080-20	CAP**3017A**	1.02	0.90	58MVB100-20
FF1ENP030	0.98	1.00	58MVB100-20	CNPV*2417A**	0.98	0.90	58MVB120-20
FV4BNF002	0.99	0.88	58MVB120-20	CNPV*3017A**	1.02	0.90	58UUV060-14
FV4BNF003	0.99	0.86	58UUV060-14	CNPV*2417A**	0.98	0.90	58UUV060-14
FX4CNF024	0.99	0.91	58UUV060-14	CNPV*3017A**	1.02	0.90	58UUV060-14
FX4CNF030	1.00	0.88	58UUV060-14	CNPV*2417A**	0.98	0.90	58UUV060-14
FY4ANF024	0.98	1.00	58UUV060-14	CNPV*3017A**	1.02	0.90	58UUV060-14
FY4ANF030	0.98	0.98	58UUV060-14	CNPV*2417A**	0.98	0.90	58UUV060-14
CAP**2414A**	0.97	0.89	58UUV060-14	CNPV*3017A**	1.02	0.90	58UUV060-14
CAP**3014A**	1.02	0.90	58UUV060-14	CNPV*2417A**	0.98	0.90	58UUV060-14
CNPV*2417A**	0.98	0.90	58UUV060-14	CNPV*3017A**	1.02	0.90	58UUV060-14
CNPV*3017A**	1.02	0.90	58UUV060-14	CNPV*2417A**	0.98	0.90	58UUV060-14
CNPV*2414A**	0.97	0.89	58UUV060-14	CNPV*3017A**	1.02	0.90	58UUV060-14
CSPH*2412A**	0.97	0.89	58UUV060-14	CNPV*2417A**	0.98	0.90	58UUV060-14
CSPH*3012A**	1.02	0.90	58UUV060-14	CNPV*3017A**	1.02	0.90	58UUV060-14
CNPV*2414A**	0.97	0.89	58UUV060-14	CNPV*2417A**	0.98	0.90	58UUV060-14
CNPV*3014A**	1.02	0.94	58UUV060-14	CNPV*3017A**	1.02	0.90	58UUV060-14
CSPH*2412A**	0.97	0.89	58UUV060-14	CNPV*2417A**	0.98	0.90	58UUV060-14
CSPH*3012A**	1.02	0.90	58UUV060-14	CNPV*3017A**	1.02	0.90	58UUV060-14
CAP**3017A**	1.02	0.90	58UUV060-14	CNPV*2417A**	0.98	0.90	58UUV060-14
CNPV*2417A**	0.98	0.90	58UUV060-14	CNPV*3017A**	1.02	0.90	58UUV060-14

See notes on pg. 23

# DETAILED COOLING CAPACITIES# (CONT.)

EVAPORATOR AIR		CONDENSER ENTERING AIR TEMPERATURES deg ° F (° C)																	
CFM	EWB	75 (23.9)			85 (29.4)			95 (35)			105 (40.6)			115 (46.1)			125 (51.7)		
		Capacity MBtuht	Sens†	Total System KW**	Capacity MBtuht	Sens†	Total System KW**	Capacity MBtuht	Sens†	Total System KW**	Capacity MBtuht	Sens†	Total System KW**	Capacity MBtuht	Sens†	Total System KW**	Capacity MBtuht	Sens†	Total System KW**
		34.45	17.52	1.98	32.96	16.97	2.19	31.38	16.38	2.43	29.70	15.77	2.69	27.90	15.12	2.98	25.90	14.41	3.29
		31.35	21.43	1.98	29.98	20.86	2.19	28.53	20.27	2.43	26.98	19.65	2.69	25.32	18.99	2.97	23.50	18.28	3.29
<b>875</b>		29.13	20.73	1.99	27.84	20.16	2.20	26.47	19.56	2.43	25.02	18.94	2.69	23.45	18.27	2.97	21.72	17.55	3.28
		28.63	25.33	1.98	27.39	24.75	2.19	26.10	24.15	2.43	24.74	23.49	2.69	23.36	23.36	2.97	21.98	21.98	3.29
		27.79	27.79	1.98	26.80	26.80	2.19	25.74	25.74	2.43	24.61	24.61	2.69	23.37	23.37	2.97	21.98	21.98	3.29
		35.09	18.37	2.02	33.53	17.80	2.24	31.88	17.21	2.47	30.14	16.59	2.73	28.26	15.93	3.02	26.19	15.21	3.34
		31.95	22.78	2.02	30.51	22.21	2.24	29.00	21.61	2.47	27.40	20.98	2.73	25.69	20.31	3.02	23.80	19.58	3.33
<b>1000</b>		29.69	22.00	2.03	28.34	21.42	2.24	26.92	20.82	2.48	25.42	20.18	2.73	23.79	19.50	3.02	22.02	18.76	3.33
		29.30	27.18	2.02	28.05	26.57	2.23	26.73	26.73	2.47	25.55	25.55	2.73	24.22	24.22	3.02	22.74	22.74	3.33
		28.96	28.96	2.02	27.89	27.89	2.23	26.76	26.76	2.47	25.55	25.55	2.73	24.22	24.22	3.02	22.75	22.75	3.33
		35.55	19.16	2.07	33.94	18.59	2.28	32.23	17.98	2.52	30.44	17.35	2.78	28.51	16.69	3.07	26.38	15.95	3.38
		32.39	24.07	2.07	30.91	23.49	2.28	29.36	22.89	2.52	27.71	22.25	2.78	25.95	21.57	3.07	24.03	20.81	3.38
<b>1125</b>		30.11	23.21	2.08	28.73	22.63	2.29	27.27	22.01	2.52	25.72	21.36	2.78	24.05	20.67	3.06	22.24	19.90	3.37
		29.94	29.71	2.07	28.80	28.80	2.28	27.60	27.60	2.52	26.31	26.31	2.78	24.91	24.91	3.07	23.36	23.36	3.38
		29.92	29.92	2.07	28.80	28.80	2.28	27.60	27.60	2.52	26.31	26.31	2.78	24.91	24.91	3.06	23.36	23.36	3.38

24ABA430A31 Outdoor Section With CAP\*\*3014A\*\* Indoor Section

Cooling Indoor Model	Capacity	Power	Furnace Model
CSPH*3012A**	0.99	0.95	58CV(A.X)070-12
CSPH*3612A**	0.99	0.92	58CV(A.X)070-12
CAP**3017A**	0.99	0.92	58CV(A.X)090-16
CAP**3617A**	1.00	0.92	58CV(A.X)090-16
CNPV*3017A**	0.99	0.95	58CV(A.X)090-16
CNPV*3617A**	1.00	0.96	58CV(A.X)090-16
CAP**3621A**	1.00	0.92	58CV(A.X)110-20
CNPV*3621A**	1.00	0.96	58CV(A.X)110-20
CNPV*3017A**	0.99	0.95	58MV040-14
CNPV*3617A**	1.00	0.95	58MV040-14
CSPH*3012A**	0.99	0.95	58MV040-14
CSPH*3612A**	0.99	0.92	58MV040-14
CAP**3017A**	0.99	0.95	58MV060-14
CAP**3617A**	0.99	0.92	58MV060-14
CNPV*3017A**	0.99	0.95	58MV060-14
CNPV*3617A**	0.99	0.95	58MV060-14
CAP**3621A**	1.00	0.96	58MV080-14
CNPV*3621A**	1.00	0.96	58MV080-14
CNPV*3017A**	0.99	0.95	58MV120-20
CAP**3017A**	0.99	0.95	58UV060-14
CAP**3617A**	0.99	0.92	58UV060-14
CNPV*3017A**	0.99	0.95	58UV060-14
CNPV*3617A**	0.99	0.95	58UV060-14
CAP**3621A**	1.00	0.96	58UV080-14
CNPV*3621A**	1.00	0.96	58UV080-14

See notes on pg. 23

Cooling Indoor Model	Capacity	Power	Furnace Model
*CAP**3014A**	1.00	1.00	
CAP**3017A**	1.00	1.04	
CAP**3614A**	0.97	1.01	
CAP**3617A**	1.01	1.05	
CAP**3621A**	1.01	1.05	
CNPF*3618A**	1.01	1.04	
CNPV*3017A**	1.00	1.04	
CNPV*3617A**	1.01	1.05	
CNPV*3014A**	1.00	1.04	
CNPV*3617A**	1.01	1.05	
CNPV*3012A**	1.01	1.05	
CSPH*3012A**	1.00	1.04	
CSPH*3612A**	1.01	1.05	
FF1ENP030	0.99	1.03	
FF1ENP036	1.01	1.05	
FV4BNF002	1.00	0.96	
FV4BNF003	1.01	0.93	
FV4BNF005	1.03	0.94	
FX4CN(B,F)036	1.02	0.98	
FX4CNF030	1.01	0.97	
FY4ANF030	0.99	1.04	
FY4ANF036	1.00	1.04	
CAP**3014A**	0.99	0.95	58CV(A.X)070-12
CAP**3614A**	0.96	0.92	58CV(A.X)070-12
CNPV*3017A**	0.99	0.95	58CV(A.X)070-12
CNPV*3617A**	0.99	0.95	58CV(A.X)070-12
CNPV*3014A**	0.99	0.95	58CV(A.X)070-12

24ABA4

DETAILED COOLING CAPACITIES# (CONT.)

EVAPORATOR AIR		CONDENSER ENTERING AIR TEMPERATURES deg °F (°C)																							
		75 (23.9)				85 (29.4)				95 (35)				105 (40.6)				115 (46.1)				125 (51.7)			
		Capacity MBtu/h		Total System KW**		Capacity MBtu/h		Total System KW**		Capacity MBtu/h		Total System KW**		Capacity MBtu/h		Total System KW**		Capacity MBtu/h		Total System KW**		Capacity MBtu/h		Total System KW**	
Total	Sens†	Total	Sens†	Total	Sens†	Total	Sens†	Total	Sens†	Total	Sens†	Total	Sens†	Total	Sens†	Total	Sens†	Total	Sens†	Total	Sens†	Total	Sens†		
CFM	EWB	24ABA436A31 Outdoor Section With CAP**4221A** Indoor Section																							
72		42.83	22.38	2.35	2.40	40.92	21.65	2.63	2.68	38.92	20.89	2.94	2.99	36.78	20.09	3.29	3.34	34.47	19.23	3.68	3.73	31.94	18.31	4.12	
67		38.83	27.27	2.35	2.40	37.06	26.52	2.63	2.68	35.20	25.74	2.94	2.99	33.22	24.93	3.29	3.34	31.08	24.06	3.68	3.73	28.75	23.12	4.12	
62		35.34	32.16	2.35	2.40	33.74	31.40	2.63	2.68	32.07	30.59	2.94	2.99	30.32	29.72	3.29	3.34	28.58	28.58	3.68	3.73	26.83	26.83	4.12	
57		34.26	34.26	2.35	2.40	32.98	32.98	2.63	2.68	31.63	31.63	2.94	2.99	30.17	30.17	3.29	3.34	28.58	28.58	3.68	3.73	26.83	26.83	4.12	
72		43.66	23.46	2.40	2.40	41.67	22.71	2.68	2.68	39.58	21.94	2.99	2.99	37.36	21.12	3.34	3.34	34.96	20.26	3.73	3.73	32.33	19.32	4.17	
67		39.58	28.97	2.40	2.40	37.74	28.21	2.68	2.68	35.80	27.42	2.99	2.99	33.75	26.59	3.34	3.34	31.55	25.71	3.73	3.73	29.14	24.76	4.17	
62		36.18	34.48	2.40	2.40	34.56	33.67	2.68	2.68	32.87	32.87	2.99	2.99	31.35	31.35	3.34	3.34	29.67	29.67	3.73	3.73	27.80	27.80	4.17	
57		35.72	35.72	2.40	2.40	34.36	34.36	2.68	2.68	32.91	32.91	2.99	2.99	31.36	31.36	3.34	3.34	29.67	29.67	3.73	3.73	27.80	27.80	4.17	
72		44.27	24.46	2.45	2.45	42.22	23.70	2.73	2.73	40.06	22.91	3.05	3.05	37.77	22.09	3.40	3.40	35.31	21.21	3.79	3.79	32.61	20.26	4.22	
67		40.14	30.57	2.45	2.45	38.24	29.80	2.73	2.73	36.25	29.01	3.04	3.04	34.15	28.17	3.39	3.39	31.89	27.28	3.78	3.78	29.44	26.29	4.22	
62		36.97	36.59	2.45	2.45	35.49	35.49	2.73	2.73	33.97	33.97	3.04	3.04	32.33	32.33	3.39	3.39	30.56	30.56	3.78	3.78	28.59	28.59	4.22	
57		36.94	36.94	2.45	2.45	35.50	35.50	2.73	2.73	33.97	33.97	3.04	3.04	32.34	32.34	3.39	3.39	30.56	30.56	3.78	3.78	28.60	28.60	4.22	

Cooling Indoor Model	Capacity	Power	Furnace Model	Cooling Indoor Model	Capacity	Power	Furnace Model	Cooling Indoor Model	Capacity	Power	Furnace Model	Cooling Indoor Model	Capacity	Power	Furnace Model	Cooling Indoor Model	Capacity	Power	Furnace Model
*CAP**4221A**	1.00	1.00		CAP**3617A**	0.98	0.96	58CV(A,X)070-12	CAP**4221A**	0.98	0.96	58CV(A,X)090-16	CAP**4221A**	0.98	0.96	58MV080-14	CAP**4221A**	0.98	0.96	58MV080-14
CAP**3614A**	0.98	0.98		CNPH*3617A**	0.98	0.94	58CV(A,X)070-12	CNPH*4221A**	0.98	0.94	58CV(A,X)090-16	CNPH*4221A**	0.98	0.94	58MV100-20	CNPH*4221A**	0.98	0.94	58MV100-20
CAP**3617A**	0.99	0.99		CNPH*4221A**	0.99	0.95	58CV(A,X)070-12	CSPH*3617A**	1.00	0.96	58CV(A,X)070-12	CSPH*4221A**	1.01	0.95	58MV120-20	CSPH*4221A**	1.01	0.95	58MV120-20
CAP**3621A**	0.99	0.99		CSPH*4221A**	1.01	0.96	58CV(A,X)070-12	CNPV*3617A**	0.98	0.94	58CV(A,X)070-12	CNPV*4221A**	0.98	0.94	58MV080-14	CNPV*4221A**	0.98	0.94	58MV080-14
CAP**4224A**	1.00	1.00		CNPV*3617A**	0.98	0.94	58CV(A,X)090-16	CNPV*4224A**	0.99	0.95	58CV(A,X)110-20	CNPV*4224A**	0.99	0.95	58MV080-20	CNPV*4224A**	0.99	0.95	58MV080-20
CNPF*3618A**	0.99	0.99		CNPV*4221A**	0.99	0.95	58CV(A,X)110-20	CNPF*3617A**	0.98	0.94	58CV(A,X)135-22	CNPF*4221A**	0.98	0.94	58MV060-14	CNPF*4221A**	0.98	0.94	58MV060-14
CNPH*3617A**	0.99	0.99		CNPH*4221A**	0.99	0.95	58CV(A,X)135-22	CNPH*4224A**	0.99	0.95	58CV(A,X)155-22	CNPH*4224A**	0.99	0.95	58MV080-14	CNPH*4224A**	0.99	0.95	58MV080-14
CNPH*4221A**	1.00	1.00		CAP**3621A**	0.98	0.94	58CV(A,X)110-20	CAP**4222A**	0.98	0.94	58MV040-14	CAP**4222A**	0.98	0.94	58MV040-14	CAP**4222A**	0.98	0.94	58MV040-14
CNPV*3617A**	0.99	0.99		CAP**4221A**	0.99	0.95	58CV(A,X)110-20	CNPH*3617A**	0.97	0.96	58MV040-14	CNPH*3617A**	0.97	0.96	58MV040-14	CNPH*3617A**	0.97	0.96	58MV040-14
CNPV*3621A**	0.99	0.99		CNPV*3621A**	0.98	0.94	58CV(A,X)110-20	CNPH*4221A**	0.99	0.95	58MV040-14	CNPH*4221A**	0.99	0.95	58MV040-14	CNPH*4221A**	0.99	0.95	58MV040-14
CNPV*4221A**	1.00	1.00		CNPV*4221A**	0.99	0.95	58CV(A,X)110-20	CSPH*3617A**	1.00	0.96	58MV040-14	CSPH*3617A**	1.00	0.96	58MV040-14	CSPH*3617A**	1.00	0.96	58MV040-14
CSPH*3612A**	1.01	1.01		CNPV*4224A**	0.99	0.95	58CV(A,X)135-22	CSPH*4212A**	1.00	0.96	58MV060-14	CSPH*4212A**	1.00	0.96	58MV060-14	CSPH*4212A**	1.00	0.96	58MV060-14
CSPH*4212A**	1.02	1.02		CNPH*4221A**	0.99	0.95	58CV(A,X)155-22	CNPV*3617A**	0.98	0.94	58MV060-14	CNPV*3617A**	0.98	0.94	58MV060-14	CNPV*3617A**	0.98	0.94	58MV060-14
FF1ENP036	0.98	0.98		CNPH*4224A**	0.99	0.95	58CV(A,X)155-22	FF1ENP036	0.98	0.98	58MV060-14	FF1ENP036	0.98	0.98	58MV060-14	FF1ENP036	0.98	0.98	58MV060-14
FV4BNB006	1.03	0.90		CAP**4222A**	0.98	0.94	58MV040-14	FV4BNB006	0.98	0.94	58MV040-14	FV4BNB006	0.98	0.94	58MV040-14	FV4BNB006	0.98	0.94	58MV040-14
FV4BNF002	0.98	0.94		CNPH*3617A**	0.97	0.96	58MV040-14	FV4BNF002	0.98	0.94	58MV040-14	FV4BNF002	0.98	0.94	58MV040-14	FV4BNF002	0.98	0.94	58MV040-14
FV4BNF003	0.99	0.95		CNPH*4221A**	0.99	0.95	58MV040-14	FV4BNF003	0.99	0.95	58MV040-14	FV4BNF003	0.99	0.95	58MV040-14	FV4BNF003	0.99	0.95	58MV040-14
FV4BNF005	1.02	0.90		CNPH*4224A**	0.99	0.95	58MV040-14	FV4BNF005	1.02	0.90	58MV040-14	FV4BNF005	1.02	0.90	58MV040-14	FV4BNF005	1.02	0.90	58MV040-14
FX4CN(B,F)036	1.01	0.96		CSPH*3617A**	1.00	0.96	58MV040-14	FX4CN(B,F)036	1.01	0.96	58MV040-14	FX4CN(B,F)036	1.01	0.96	58MV040-14	FX4CN(B,F)036	1.01	0.96	58MV040-14
FX4CN(B,F)042	1.02	0.98		CAP**3617A**	0.98	0.94	58MV060-14	FX4CN(B,F)042	1.02	0.98	58MV060-14	FX4CN(B,F)042	1.02	0.98	58MV060-14	FX4CN(B,F)042	1.02	0.98	58MV060-14
FY4ANF036	0.97	1.01		CNPV*3617A**	0.98	0.94	58MV060-14	FY4ANF036	0.97	1.01	58MV060-14	FY4ANF036	0.97	1.01	58MV060-14	FY4ANF036	0.97	1.01	58MV060-14
FY4ANF042	1.01	1.01		CNPV*4224A**	0.98	0.95	58MV060-14	FY4ANF042	1.01	1.01	58MV060-14	FY4ANF042	1.01	1.01	58MV060-14	FY4ANF042	1.01	1.01	58MV060-14

See notes on pg. 23

# DETAILED COOLING CAPACITIES# (CONT.)

EVAPORATOR AIR		CONDENSER ENTERING AIR TEMPERATURES deg ° F (° C)																	
		75 (23.9)		85 (29.4)		95 (35)		105 (40.6)		115 (46.1)		125 (51.7)							
CFM	EWB	Capacity MBtu/h		Total System KW**	Capacity MBtu/h		Total System KW**	Capacity MBtu/h		Total System KW**	Capacity MBtu/h		Total System KW**						
		Total	Sens†		Total	Sens†		Total	Sens†		Total	Sens†							
<b>24ABA442A32 Outdoor Section With CAP**4821A* Indoor Section</b>																			
72		47.98	25.11	2.73	45.92	24.33	3.01	43.69	23.50	3.33	41.29	22.62	3.69	38.70	21.67	4.09	35.85	20.65	4.54
67		43.86	30.89	2.72	41.96	30.10	2.99	39.91	29.25	3.30	37.70	28.35	3.66	35.31	27.39	4.06	32.70	26.36	4.51
62		40.13	36.62	2.70	38.41	35.80	2.97	36.57	34.93	3.29	34.63	33.95	3.64	32.73	32.73	4.04	30.75	30.75	4.49
57		39.05	39.05	2.70	37.67	37.67	2.97	36.17	36.17	3.28	34.53	34.53	3.64	32.74	32.74	4.04	30.75	30.75	4.49
72		48.78	26.33	2.80	46.63	25.53	3.08	44.31	24.69	3.40	41.82	23.79	3.76	39.14	22.83	4.16	36.19	21.80	4.61
67		44.62	32.84	2.78	42.63	32.03	3.06	40.50	31.17	3.37	38.21	30.27	3.73	35.75	29.30	4.13	33.06	28.24	4.58
62		41.02	39.28	2.77	39.28	38.40	3.04	37.54	37.54	3.36	35.79	35.79	3.72	33.88	33.88	4.12	31.76	31.76	4.57
57		40.64	40.64	2.77	39.15	39.15	3.04	37.54	37.54	3.36	35.79	35.79	3.72	33.88	33.88	4.12	31.76	31.76	4.57
72		49.37	27.47	2.87	47.14	26.67	3.15	44.75	25.81	3.47	42.19	24.90	3.83	39.43	23.94	4.23	36.41	22.89	4.68
67		45.17	34.70	2.85	43.12	33.88	3.13	40.93	33.02	3.44	38.58	32.10	3.80	36.05	31.11	4.20	33.31	30.02	4.65
62		41.89	41.89	2.84	40.34	40.34	3.11	38.64	38.64	3.43	36.79	36.79	3.79	34.77	34.77	4.19	32.54	32.54	4.64
57		41.91	41.91	2.84	40.34	40.34	3.11	38.64	38.64	3.43	36.79	36.79	3.79	34.78	34.78	4.19	32.54	32.54	4.64

Cooling Indoor Model	Capacity	Power	Furnace Model	Cooling Indoor Model	Capacity	Power	Furnace Model	Cooling Indoor Model	Capacity	Power	Furnace Model
CAP**4221A**	0.99	1.01	58CV(A,X)110-20	CSPH*4821A**	1.00	0.96	58CV(A,X)110-20	CNPV*4221A**	0.98	0.96	58MV080-20
CAP**4224A**	0.99	1.01	58CV(A,X)135-22	CAP**4224A**	0.98	0.94	58CV(A,X)135-22	CNPV*4821A**	0.99	0.97	58MV080-20
CAP**4824A**	0.98	0.96	58CV(A,X)135-22	CAP**4824A**	0.99	0.95	58CV(A,X)135-22	CSPH*4821A**	0.98	0.96	58MV080-20
CAP**4824A**	1.00	1.00	58CV(A,X)135-22	CNPH*4221A**	0.98	0.94	58CV(A,X)135-22	CSPH*4821A**	1.00	0.98	58MV080-20
CNPH*4818A**	0.98	1.02	58CV(A,X)135-22	CNPH*4821A**	1.00	0.96	58CV(A,X)135-22	CAP**4221A**	0.98	0.96	58MV100-20
CNPH*4221A**	0.99	1.01	58CV(A,X)135-22	CNPV*4824A**	1.00	0.96	58CV(A,X)135-22	CAP**4821A**	0.99	0.95	58MV100-20
CNPH*4221A**	1.00	1.00	58CV(A,X)135-22	CSPH*4212A**	0.99	0.95	58CV(A,X)135-22	CNPH*4221A**	0.99	0.96	58MV100-20
CNPH*4221A**	0.99	1.01	58CV(A,X)155-22	CNPH*4812A**	1.00	0.96	58CV(A,X)155-22	CNPH*4821A**	0.99	0.96	58MV100-20
CNPH*4821A**	1.00	1.00	58CV(A,X)155-22	CAP**4224A**	0.98	0.94	58CV(A,X)155-22	CNPV*4821A**	0.98	0.96	58MV100-20
CNPH*4824A**	1.00	1.00	58CV(A,X)155-22	CAP**4824A**	0.99	0.95	58CV(A,X)155-22	CNPV*4821A**	0.99	0.95	58MV100-20
CSPH*4212A**	0.99	1.01	58CV(A,X)155-22	CNPH*4221A**	0.98	0.94	58CV(A,X)155-22	CSPH*4212A**	0.99	0.97	58MV100-20
FE4AN(B,F)003	0.98	1.00	58CV(A,X)155-22	CNPH*4821A**	1.00	0.96	58CV(A,X)155-22	CSPH*4812A**	1.00	0.96	58MV100-20
FE4AN(B,F)005	1.01	0.93	58CV(A,X)155-22	CNPH*4821A**	0.99	0.95	58CV(A,X)155-22	CAP**4224A**	0.98	0.95	58MV120-20
FE4AN(B,F)006	1.02	0.95	58CV(A,X)155-22	CSPH*4812A**	1.00	0.96	58CV(A,X)155-22	CAP**4824A**	0.99	0.96	58MV120-20
FE5AN(B,F)004	1.02	0.95	58MV040-14	CAP**4224A**	0.96	0.95	58MV040-14	CNPH*4821A**	0.99	0.95	58MV120-20
FV4BN(B,F)003	0.98	0.94	58MV040-14	CAP**4824A**	0.99	0.97	58MV040-14	CNPV*4824A**	0.99	0.95	58MV120-20
FV4BN(B,F)005	1.01	0.93	58MV040-14	CNPH*4221A**	0.98	0.98	58MV040-14	CSPH*4212A**	0.98	0.96	58MV120-20
FV4BN(B,F)006	1.02	0.95	58MV040-14	CNPH*4821A**	0.99	0.97	58MV040-14	CSPH*4812A**	1.00	0.96	58MV120-20
FX4CN(B,F)042	1.00	0.98	58MV040-14	CNPV*4821A**	0.99	0.97	58MV040-14	CAP**4817A**	0.96	0.95	58UV080-14
FX4CN(B,F)048	1.02	0.98	58MV040-14	CNPV*4821A**	0.98	0.96	58MV040-14	CAP**4221A**	0.99	0.96	58UV080-14
FY4AN(F)042	0.99	1.01	58MV040-14	CSPH*4812A**	0.99	0.97	58MV040-14	CAP**4821A**	0.99	0.97	58UV080-14
FY4AN(F)048	1.01	1.01	58MV040-14	CAP**4817A**	0.96	0.95	58MV040-14	CAP**4821A**	0.99	0.97	58UV080-14
CNPH*4221A**	0.98	0.98	58CV(A,X)070-12	CNPH*4221A**	0.98	0.96	58MV060-14	CNPV*4221A**	0.96	0.96	58UV080-14
CNPH*4821A**	0.99	0.97	58CV(A,X)070-12	CNPH*4821A**	0.99	0.96	58MV060-14	CNPV*4821A**	0.99	0.97	58UV080-14
CSPH*4212A**	0.98	0.96	58CV(A,X)070-12	CSPH*4821A**	0.98	0.96	58MV060-14	CAP**4221A**	0.98	0.96	58UV080-14
CSPH*4812A**	1.00	0.98	58CV(A,X)070-12	CSPH*4812A**	0.98	0.96	58MV060-14	CAP**4821A**	0.99	0.97	58UV080-14
CAP**4817A**	0.98	0.94	58CV(A,X)090-16	CSPH*4812A**	1.00	0.98	58MV060-14	CNPV*4221A**	0.99	0.96	58UV080-20
CNPH*4221A**	0.98	0.96	58CV(A,X)090-16	CAP**4221A**	0.96	0.96	58MV060-14	CNPV*4821A**	0.99	0.97	58UV080-20
CNPH*4821A**	0.99	0.95	58CV(A,X)090-16	CAP**4821A**	0.99	0.97	58MV060-14	CAP**4221A**	0.98	0.96	58UV100-20
CSPH*4212A**	0.99	0.97	58CV(A,X)090-16	CNPH*4821A**	0.99	0.97	58MV060-14	CNPV*4221A**	0.99	0.96	58UV100-20
CSPH*4812A**	1.00	0.98	58CV(A,X)110-20	CNPH*4221A**	0.98	0.96	58MV060-14	CAP**4821A**	0.99	0.95	58UV100-20
CAP**4221A**	0.98	0.96	58CV(A,X)110-20	CNPH*4821A**	0.99	0.97	58MV060-14	CNPV*4221A**	0.99	0.96	58UV100-20
CAP**4821A**	0.99	0.95	58CV(A,X)110-20	CSPH*4812A**	0.98	0.96	58MV060-14	CAP**4224A**	0.98	0.96	58UV120-20
CNPH*4821A**	1.00	0.96	58CV(A,X)110-20	CAP**4221A**	0.98	0.96	58MV060-14	CAP**4824A**	0.99	0.95	58UV120-20
CNPV*4221A**	0.98	0.96	58CV(A,X)110-20	CAP**4821A**	0.99	0.97	58MV060-14	CNPV*4824A**	0.99	0.95	58UV120-20
CNPV*4821A**	1.00	0.96	58CV(A,X)110-20	CNPH*4221A**	0.98	0.96	58MV060-14				

See notes on pg. 23

DETAILED COOLING CAPACITIES# (CONT.)

EVAPORATOR AIR		CONDENSER ENTERING AIR TEMPERATURES deg ° F (° C)																	
		75 (23.9)			85 (29.4)			95 (35)			105 (40.6)			115 (46.1)			125 (51.7)		
		Capacity MBtu/h		Total System KW**	Capacity MBtu/h		Total System KW**	Capacity MBtu/h		Total System KW**	Capacity MBtu/h		Total System KW**	Capacity MBtu/h		Total System KW**	Capacity MBtu/h		Total System KW**
CFM	EWB	Total	Sens†	Total	Sens†	Total	Sens†	Total	Sens†	Total	Sens†	Total	Sens†	Total	Sens†	Total	Sens†	Total	
<b>24ABA448A32 Outdoor Section With CAP**6024A* Indoor Section</b>																			
	72	57.54	29.08	3.21	54.90	28.10	3.66	52.22	27.11	4.12	49.43	26.10	4.59	46.45	25.03	43.18	23.88	5.66	
1400	67	52.60	35.60	3.24	50.19	34.61	3.67	47.73	33.61	4.10	45.16	32.59	4.55	42.41	31.50	39.39	30.33	5.62	
	62	48.14	42.09	3.26	45.96	41.09	3.66	43.75	40.07	4.08	41.45	38.99	4.52	39.05	39.05	36.77	36.77	5.60	
	57	46.53	46.53	3.26	44.80	44.80	3.66	43.02	43.02	4.07	41.12	41.12	4.52	39.07	39.07	36.78	36.78	5.60	
1600	72	58.61	30.51	3.27	55.84	29.50	3.73	53.03	28.50	4.19	50.13	27.47	4.66	47.05	26.39	43.66	25.22	5.73	
	67	53.60	37.88	3.30	51.07	36.87	3.74	48.50	35.86	4.17	45.83	34.81	4.63	42.99	33.72	39.87	32.52	5.70	
	62	49.23	45.22	3.32	46.99	44.16	3.74	44.76	44.49	4.16	42.68	42.68	4.61	40.49	40.49	39.05	39.05	5.08	
	57	48.50	48.50	3.33	46.64	46.64	3.74	44.71	44.71	4.16	42.68	42.68	4.61	40.49	40.49	38.05	38.05	5.68	
1800	72	59.39	31.85	3.33	56.53	30.84	3.80	53.62	29.81	4.26	50.63	28.77	4.74	47.46	27.68	43.97	26.49	5.81	
	67	54.34	40.06	3.36	51.71	39.04	3.81	49.07	38.02	4.25	46.32	36.96	4.71	43.41	35.84	40.23	34.61	5.78	
	62	50.22	49.72	3.39	48.14	48.14	3.81	46.10	46.10	4.24	43.95	43.95	4.69	41.64	41.64	39.06	39.06	5.77	
	57	50.12	50.12	3.39	48.14	48.14	3.81	46.10	46.10	4.23	43.95	43.95	4.69	41.64	41.64	39.07	39.07	5.77	

Cooling Indoor Model	Capacity	Power	Furnace Model	Cooling Indoor Model	Capacity	Power	Furnace Model	Cooling Indoor Model	Capacity	Power	Furnace Model	Cooling Indoor Model	Capacity	Power	Furnace Model	Cooling Indoor Model	Capacity	Power	Furnace Model
*CAP**6024A**	1.00	1.00		CSPH**4812A**	0.98	0.94	58CV(A,X)110-20	CSPH**4812A**	0.98	0.94	58CV(A,X)110-20	CSPH**6012A**	1.00	0.94	58CV(A,X)110-20	CSPH**6012A**	1.00	0.96	58MVB100-20
CAP**4817A**	0.97	0.97		CSPH**6012A**	1.00	0.94	58CV(A,X)135-22	CSPH**6012A**	1.00	0.94	58CV(A,X)135-22	CAP**4824A**	0.98	0.94	58CV(A,X)135-22	CAP**4824A**	0.99	0.95	58MVB120-20
CAP**4821A**	0.99	1.01		CAP**4824A**	0.98	0.94	58CV(A,X)135-22	CAP**4824A**	0.98	0.94	58CV(A,X)135-22	CAP**6021A**	0.99	0.94	58CV(A,X)135-22	CAP**6021A**	0.99	0.95	58MVB120-20
CAP**4824A**	0.99	1.01		CNPV**4821A**	0.98	0.94	58CV(A,X)135-22	CNPV**4821A**	0.98	0.94	58CV(A,X)135-22	CNPV**4821A**	0.98	0.94	58CV(A,X)135-22	CNPV**4821A**	0.99	0.95	58MVB120-20
CNPV**4818A**	0.97	0.99		CNPV**6024A**	1.00	1.00	58CV(A,X)135-22	CNPV**6024A**	1.00	0.99	58CV(A,X)135-22	CNPV**4821A**	0.98	0.94	58CV(A,X)135-22	CNPV**4821A**	0.99	0.95	58MVB120-20
CNPV**4821A**	0.99	1.01		CNPV**4824A**	0.99	0.94	58CV(A,X)135-22	CNPV**4824A**	0.99	0.94	58CV(A,X)135-22	CNPV**6012A**	1.00	0.94	58CV(A,X)135-22	CNPV**6012A**	1.00	0.96	58MVB120-20
CNPV**6024A**	1.00	1.00		CSPH**4812A**	1.00	0.94	58CV(A,X)155-22	CSPH**4812A**	1.00	0.94	58CV(A,X)155-22	CSPH**4812A**	1.00	0.94	58CV(A,X)155-22	CSPH**4812A**	1.00	0.97	58UJB080-20
CSPH**4812A**	0.99	1.01		CAP**4824A**	0.98	0.94	58CV(A,X)155-22	CAP**4824A**	0.98	0.94	58CV(A,X)155-22	CAP**6021A**	0.99	0.94	58CV(A,X)155-22	CAP**6021A**	0.99	0.95	58UJB080-20
CNPV**6012A**	1.00	1.00		CNPV**4821A**	0.98	0.94	58CV(A,X)155-22	CNPV**4821A**	0.98	0.94	58CV(A,X)155-22	CNPV**4821A**	0.98	0.94	58CV(A,X)155-22	CNPV**4821A**	0.99	0.95	58UJB100-20
FE4AN(B,F)005	1.00	1.00		CNPV**6024A**	1.00	1.00	58CV(A,X)155-22	CNPV**6024A**	1.00	0.94	58CV(A,X)155-22	CNPV**6024A**	1.00	0.94	58CV(A,X)155-22	CNPV**6024A**	0.99	0.95	58UJB100-20
FE4AN(B,F)005	1.00	0.90		CNPV**4824A**	0.98	0.94	58CV(A,X)155-22	CNPV**4824A**	0.98	0.94	58CV(A,X)155-22	CNPV**4824A**	0.98	0.94	58CV(A,X)155-22	CNPV**4824A**	0.99	0.95	58UJB100-20
FE4AN(B,F)005	1.00	0.94		CNPV**6024A**	1.00	0.94	58CV(A,X)155-22	CNPV**6024A**	1.00	0.94	58CV(A,X)155-22	CNPV**6024A**	1.00	0.94	58CV(A,X)155-22	CNPV**6024A**	0.99	0.95	58UJB100-20
FV4BNB006	1.00	0.90		CSPH**4812A**	1.00	0.94	58CV(A,X)155-22	CSPH**4812A**	1.00	0.94	58CV(A,X)155-22	CSPH**4812A**	1.00	0.94	58CV(A,X)155-22	CSPH**4812A**	1.00	0.97	58UJB120-20
FV4BNB006	1.00	0.90		CSPH**6012A**	1.00	0.96	58CV(A,X)155-22	CSPH**6012A**	1.00	0.94	58CV(A,X)155-22	CSPH**6012A**	1.00	0.94	58CV(A,X)155-22	CSPH**6012A**	1.00	0.95	58UJB120-20
FV4BNB006	1.00	0.96		CAP**4821A**	1.02	0.96	58CV(A,X)155-22	CAP**4821A**	1.02	0.96	58CV(A,X)155-22	CAP**4821A**	1.02	0.96	58CV(A,X)155-22	CAP**4821A**	1.02	0.95	58UJB120-20
FV4ANB060	1.00	1.00		CAP**6021A**	1.00	1.00	58MVB080-20	CAP**6021A**	0.99	0.95	58MVB080-20	CAP**6021A**	0.99	0.95	58MVB080-20	CAP**6021A**	0.99	0.95	58UJB120-20
FV4ANB060	1.00	1.02		CNPV**4821A**	0.97	0.94	58MVB080-20	CNPV**4821A**	0.97	0.94	58MVB080-20	CNPV**4821A**	0.97	0.94	58MVB080-20	CNPV**4821A**	0.99	0.95	58UJB120-20
CAP**4817A**	0.97	0.94	58CV(A,X)090-16	CNPV**6024A**	1.00	1.00	58MVB080-20	CNPV**6024A**	0.99	0.95	58MVB080-20	CNPV**6024A**	1.00	0.94	58MVB080-20	CNPV**6024A**	0.99	0.95	58UJB120-20
CNPV**4821A**	0.98	0.95	58CV(A,X)090-16	CNPV**4821A**	0.99	0.94	58MVB080-20	CNPV**4821A**	0.99	0.94	58MVB080-20	CNPV**4821A**	0.99	0.94	58MVB080-20	CNPV**4821A**	0.99	0.95	58UJB120-20
CNPV**6024A**	0.99	0.95	58CV(A,X)090-16	CNPV**6024A**	0.98	0.95	58MVB080-20	CNPV**6024A**	0.98	0.95	58MVB080-20	CNPV**6024A**	0.99	0.94	58MVB080-20	CNPV**6024A**	0.99	0.95	58UJB120-20
CSPH**4812A**	0.98	0.95	58CV(A,X)090-16	CSPH**4812A**	0.99	0.95	58MVB080-20	CSPH**4812A**	0.99	0.95	58MVB080-20	CSPH**4812A**	1.00	0.96	58MVB080-20	CSPH**4812A**	1.00	0.95	58UJB120-20
CSPH**6012A**	1.00	0.96	58CV(A,X)090-16	CAP**4821A**	1.00	0.94	58MVB100-20	CAP**4821A**	0.97	0.94	58MVB100-20	CAP**4821A**	0.97	0.94	58MVB100-20	CAP**4821A**	0.99	0.95	58UJB120-20
CAP**4821A**	0.97	0.94	58CV(A,X)110-20	CAP**6021A**	0.97	0.94	58MVB100-20	CAP**6021A**	0.97	0.94	58MVB100-20	CAP**6021A**	0.97	0.94	58MVB100-20	CAP**6021A**	0.99	0.95	58UJB120-20
CAP**6021A**	0.99	0.93	58CV(A,X)110-20	CNPV**4821A**	0.99	0.94	58MVB100-20	CNPV**4821A**	0.99	0.94	58MVB100-20	CNPV**4821A**	0.99	0.94	58MVB100-20	CNPV**4821A**	0.99	0.95	58UJB120-20
CNPV**4821A**	0.10	0.09	58CV(A,X)110-20	CNPV**6024A**	0.99	0.94	58MVB100-20	CNPV**6024A**	0.99	0.94	58MVB100-20	CNPV**6024A**	0.99	0.94	58MVB100-20	CNPV**6024A**	0.99	0.95	58UJB120-20
CNPV**6024A**	0.99	0.95	58CV(A,X)110-20	CSPH**4812A**	0.97	0.94	58MVB100-20	CSPH**4812A**	0.97	0.94	58MVB100-20	CSPH**4812A**	0.97	0.94	58MVB100-20	CSPH**4812A**	0.99	0.95	58UJB120-20
CNPV**4821A**	0.98	0.94	58CV(A,X)110-20																

See notes on pg. 23

# DETAILED COOLING CAPACITIES# (CONT.)

EVAPORATOR AIR		CONDENSER ENTERING AIR TEMPERATURES °F (°C)																		
		75 (23.9)			85 (29.4)			95 (35)			105 (40.6)			115 (46.1)			125 (51.7)			
		CFM	EWB	Capacity MBtuh		Total System KW	Capacity MBtuh		Total System KW	Capacity MBtuh		Total System KW	Capacity MBtuh		Total System KW	Capacity MBtuh		Total System KW		
Total	Sens			Total	Sens		Total	Sens		Total	Sens		Total	Sens						
<b>24ABA460A32 Outdoor Section With CAP**6024A* Indoor Section</b>																				
	72		70.19	36.01	4.06	66.99	34.81	4.45	63.60	33.54	4.89	59.97	32.20	5.38	56.01	30.77	5.94	51.61	29.20	6.58
1750	67		64.08	44.07	3.98	61.18	42.86	4.37	58.10	41.60	4.81	54.79	40.26	5.31	51.19	38.81	5.87	47.20	37.25	6.52
	62		58.62	52.10	3.92	56.02	50.89	4.31	53.29	49.60	4.75	50.39	48.19	5.25	47.38	47.38	5.82	44.37	44.37	6.48
	57		56.77	56.77	3.90	54.70	54.70	4.30	52.48	52.48	4.74	50.07	50.07	5.24	47.40	47.40	5.82	44.37	44.37	6.48
2000	72		71.45	37.73	4.17	68.09	36.49	4.56	64.55	35.20	4.99	60.76	33.84	5.49	56.65	32.38	6.05	52.09	30.78	6.68
	67		65.28	46.82	4.09	62.22	45.58	4.48	59.00	44.29	4.92	55.56	42.93	5.41	51.83	41.46	5.98	47.70	39.86	6.62
	62		59.93	55.85	4.03	57.26	54.54	4.42	54.51	54.11	4.86	51.85	51.85	5.36	48.98	48.98	5.94	45.74	45.74	6.59
2250	57		59.08	59.08	4.02	56.84	56.84	4.41	54.45	54.45	4.86	51.85	51.85	5.36	48.99	48.99	5.94	45.75	45.75	6.59
	72		72.38	39.33	4.27	68.90	38.08	4.66	65.23	36.77	5.10	61.32	35.38	5.59	57.08	33.90	6.15	52.40	32.29	6.78
	67		66.14	49.42	4.20	62.97	48.16	4.58	59.65	46.86	5.02	56.11	45.48	5.52	52.28	43.98	6.05	48.06	42.32	6.72
62		61.11	59.22	4.14	58.59	58.59	4.53	56.05	56.05	4.97	53.30	53.30	5.48	50.26	50.26	6.05	46.83	46.83	6.70	
57		60.98	60.98	4.14	58.59	58.59	4.53	56.05	56.05	4.97	53.30	53.30	5.48	50.27	50.27	6.05	46.84	46.84	6.70	

Cooling Indoor Model	Capacity	Power	Furnace Model	Cooling Indoor Model	Capacity	Power	Furnace Model	Cooling Indoor Model	Capacity	Power	Furnace Model	Cooling Indoor Model	Capacity	Power	Furnace Model
*CAP**6024A**	1.00	1.00		CAP**6024A**	0.98	0.98	58CV(A,X)135-22	CAP**6024A**	0.98	0.98	58CV(A,X)135-22	CAP**6024A**	0.95	0.93	58MVB100-20
CAP**6021A**	0.98	0.98		CNPH*6024A**	0.98	0.97	58CV(A,X)135-22	CNPH*6024A**	0.98	0.97	58CV(A,X)135-22	CNPH*6024A**	0.95	0.93	58MVB100-20
CNPH*6024A**	1.00	1.00		CNPH*6024A**	0.98	0.97	58CV(A,X)135-22	CNPH*6024A**	0.98	0.97	58CV(A,X)135-22	CNPH*6024A**	0.94	0.93	58MVB100-20
CNPH*6024A**	1.00	1.00		CNPH*6024A**	0.99	0.98	58CV(A,X)135-22	CNPH*6024A**	0.99	0.98	58CV(A,X)135-22	CNPH*6024A**	0.94	0.93	58MVB100-20
CSPH*6012A**	1.00	1.00		CAP**6024A**	0.98	0.97	58CV(A,X)155-22	CAP**6024A**	0.98	0.97	58CV(A,X)155-22	CNPH*6024A**	0.94	0.93	58MVB120-20
FE4ANB006	1.00	0.98		CNPH*6024A**	0.98	0.97	58CV(A,X)155-22	CNPH*6024A**	0.98	0.97	58CV(A,X)155-22	CNPH*6024A**	0.94	0.93	58MVB120-20
FV4BNB006	1.00	0.98		CNPH*6024A**	0.98	0.97	58CV(A,X)155-22	CNPH*6024A**	0.98	0.97	58CV(A,X)155-22	CNPH*6024A**	0.94	0.93	58MVB120-20
FX4CN(B,F)060	1.02	1.00		CNPH*6024A**	0.99	0.98	58CV(A,X)155-22	CNPH*6024A**	0.99	0.98	58CV(A,X)155-22	CNPH*6024A**	0.94	0.93	58MVB120-20
FY4ANB060	1.00	1.04		CAP**6021A**	0.95	0.95	58MVB080-20	CAP**6021A**	0.95	0.95	58MVB080-20	CAP**6021A**	0.95	0.93	58MVB100-20
CNPH*6024A**	0.98	0.98	58CV(A,X)110-20	CNPH*6024A**	0.94	0.94	58MVB080-20	CNPH*6024A**	0.94	0.94	58MVB080-20	CNPH*6024A**	0.94	0.93	58MVB120-20
CSPH*6012A**	0.98	0.98	58CV(A,X)110-20	CSPH*6012A**	0.94	0.94	58MVB080-20	CSPH*6012A**	0.94	0.94	58MVB080-20	CSPH*6012A**	0.94	0.93	58MVB120-20

\* Tested combination.

† Total and sensible capacities are net capacities. Blower motor heat has been subtracted.

‡ Sensible capacities shown are based on 80°F (27°C) entering air at the indoor coil. For sensible capacities at other than 80°F (27°C), deduct 835 Btuh (245 kW) per 1000 CFM (480 L/S) of indoor coil air for each degree below 80°F (27°C), or add 835 Btuh (245 kW) per 1000 CFM (480 L/S) of indoor coil air per degree above 80°F (27°C).

# Detailed cooling capacities are based on indoor and outdoor unit at the same elevation per ARI standard 210/240-94. If additional tubing length and/or indoor unit is located above outdoor unit, a slight variation in capacity may occur.

\*\* System kw is total of indoor and outdoor unit kilowatts.

EWB — Entering Wet Bulb

NOTE: When the required data fall between the published data, interpolation may be performed. Extrapolation is not an acceptable practice.



24ABA4

# GUIDE SPECIFICATIONS

## GENERAL

# AIR-COOLED, SPLIT-SYSTEM AIR CONDITIONER

## 24ABA4

### 1-1/2 TO 5 NOMINAL TONS

### System Description

Outdoor-mounted, air-cooled, split-system air conditioner unit suitable for ground or rooftop installation. Unit consists of a hermetic compressor, an air-cooled coil, propeller-type condenser fan, and a control box. Unit will discharge supply air upward as shown on contract drawings. Unit will be used in a refrigeration circuit to match up to a packaged fan coil or coil unit.

### Quality Assurance

- Unit will be rated in accordance with the latest edition of ARI Standard 210.
- Unit will be certified for capacity and efficiency, and listed in the latest ARI directory.
- Unit construction will comply with latest edition of ANSI/ASHRAE and with NEC.
- Unit will be constructed in accordance with UL standards and will carry the UL label of approval. Unit will have c-UL approval.
- Unit cabinet will be capable of withstanding Federal Test Method Standard No. 141 (Method 6061) 500-hr salt spray test.
- Air-cooled condenser coils will be leak tested and pressure tested.
- Unit constructed in ISO9001 approved facility.

### Delivery, Storage, and Handling

- Unit will be shipped as single package only and is stored and handled per unit manufacturer's recommendations.

### Warranty (for inclusion by specifying engineer)

- U.S. and Canada only.

## PRODUCTS

### Equipment

- Factory assembled, single piece, air-cooled air conditioner unit. Contained within the unit enclosure is all factory wiring, piping, controls, compressor, refrigerant charge Puron® (R-410A), and special features required prior to field start-up.

### Unit Cabinet

- Unit cabinet, including louvered coil guard, will be constructed of galvanized steel, bonderized, and coated with a powder coat paint.

### Fans

- Condenser fan will be direct-drive propeller type, discharging air upward.
- Condenser fan motors will be totally enclosed, 1-phase type with class B insulation and permanently lubricated bearings. Shafts will be corrosion resistant.
- Fan blades will be statically and dynamically balanced.
- Condenser fan openings will be equipped with coated steel wire safety guards.

### Compressor

- Compressor will be hermetically sealed.
- Compressor will be mounted on rubber vibration isolators.

### Condenser Coil

- Condenser coil will be air cooled.
- Coil will be constructed of aluminum fins mechanically bonded to copper tubes which are then cleaned, dehydrated, and sealed.

### Refrigeration Components

- Refrigeration circuit components will include liquid-line shutoff valve with sweat connections, vapor-line shutoff valve with sweat connections, system charge of Puron® (R-410A) refrigerant, and compressor oil.
- Unit will be equipped with filter drier for Puron refrigerant.

### Operating Characteristics

- The capacity of the unit will meet or exceed \_\_\_\_\_ Btuh at a suction temperature of \_\_\_\_\_ °F/°C. The power consumption at full load will not exceed \_\_\_\_\_ kW.
- Combination of the unit and the evaporator or fan coil unit will have a total net cooling capacity of \_\_\_\_\_ Btuh or greater at conditions of \_\_\_\_\_ CFM entering air temperature at the evaporator at \_\_\_\_\_ °F/°C wet bulb and \_\_\_\_\_ °F/°C dry bulb, and air entering the unit at \_\_\_\_\_ °F/°C.
- The system will have a SEER of \_\_\_\_\_ Btuh/watt or greater at DOE conditions.

### Electrical Requirements

- Nominal unit electrical characteristics will be \_\_\_\_\_ v, single phase, 60 hz. The unit will be capable of satisfactory operation within voltage limits of \_\_\_\_\_ v to \_\_\_\_\_ v.
- Unit electrical power will be single point connection.
- Control circuit will be 24v.

### Special Features

- Refer to section of this literature identifying accessories and descriptions for specific features and available enhancements.