

TRAFFIC IMPACT ANALYSIS REPORT

FOOTHILL AND LARCH
CHICK-FIL-A PROJECT

Rialto, California
August 3, 2023

Prepared for:

Chick-fil-A, Inc.
105 Progress
Irvine, CA 92618

LLG Ref. 2-23-4640-1



Prepared by:

Daniel A. Kloos, P.E.
Associate Principal
and
Christy Kopulsky
Transportation Engineer I

Under the Supervision of:

Keil D. Maberry, P.E.
Principal

**Linscott, Law &
Greenspan, Engineers**

2 Executive Circle
Suite 250

Irvine, CA 92614

949.825.6175 T

949.825.6173 F

www.llgengineers.com
www.llgengineers.com

TABLE OF CONTENTS

SECTION	PAGE
Executive Summary	vii
1.0 Introduction	1
1.1 Study Area	2
1.2 Traffic Impact Analysis Components.....	2
1.3 Traffic Impact Analysis Scenarios	3
2.0 Project Description and Location	4
2.1 Site Access	4
2.2 Project-Specific Improvements	4
3.0 Analysis Conditions and Methodology	5
3.1 Existing Street Network	5
3.2 Existing Traffic Volumes	5
3.3 Level Of Service (LOS) Analysis Methodologies	5
3.3.1 Highway Capacity Manual 7 (HCM 7) Method of Analysis (Signalized Intersections).....	6
3.3.2 Highway Capacity Manual 7 (HCM 7) Method of Analysis (Unsignalized Intersections).....	6
3.4 Impact Criteria and Thresholds	6
4.0 Traffic Forecasting Methodology	9
5.0 Project Traffic Characteristics	10
5.1 Project Trip Generation Forecast	10
5.2 Project Traffic Distribution and Assignment	10
6.0 Future Traffic Conditions	12
6.1 Existing With Project Traffic Volumes.....	12
6.2 Year 2025 With Project Traffic Volumes	12
6.2.1 Ambient Traffic Growth	12
6.2.2 Cumulative Projects Traffic Characteristics	12
6.2.3 Existing With Ambient Growth Year 2025 With Project Traffic Volumes	13
6.2.4 Existing With Ambient Growth Year 2025 With Cumulative With Project Traffic Volumes.....	13
7.0 Existing With Project Analysis	16
7.1 Existing Traffic Conditions	16
7.2 Existing With Project Traffic Conditions.....	16

TABLE OF CONTENTS (CONTINUED)

SECTION	PAGE
8.0 Existing With Ambient Growth (Year 2025) With Project Analysis	18
8.1 Existing With Ambient Growth (Year 2025) Without Project Traffic Conditions	18
8.2 Existing With Ambient Growth (Year 2025) With Project Traffic Conditions	18
9.0 Existing With A.G. (Year 2025) With Cumulative With Project Analysis.....	20
9.1 Existing With A.G. (Year 2025) With Cum Without Project Traffic Conditions.....	20
9.2 Existing With A.G. (Year 2025) With Cumulative With Project Traffic Conditions.....	20
10.0 Traffic Signal Warrant Analysis	22
10.1 Existing With A.G. (Year 2025) With Cum Without Project Traffic Conditions.....	22
10.2 Existing With A.G. (Year 2025) With Cumulative With Project Traffic Conditions.....	22
11.0 Site Access and Internal Circulation Evaluation	24
11.1 Site Access Evaluation	24
11.1.1 Queuing Evaluation	24
11.2 Internal Circulation Evaluation	24
11.3 Chick-fil-A Drive-Through	24
12.0 Recommended Improvements	32
12.1 Project-Specific Improvements	32
12.2 Existing With Project Traffic Conditions.....	32
12.3 Existing With Ambient Growth (Year 2025) With Project Traffic Conditions	32
12.4 Existing With A.G. (Year 2025) With Cumulative With Project Traffic Conditions.....	32
13.0 Fair Share Analysis.....	33
13.1 Existing With Ambient Growth With Cumulative With Project Traffic Conditions.....	33
14.0 Vehicle Miles Traveled (VMT) Assessment.....	35

APPENDICES

APPENDIX

- A. Traffic Study Scope of Work**
- B. Existing Traffic Count Data**
- C. Existing Traffic Conditions Intersection Level of Service Calculation Worksheets**
 - C-I Existing Traffic Conditions
 - C-II Existing With Project Traffic Conditions
- D. Existing With Ambient Growth Year 2025 With Project Traffic Conditions Intersection Level of Service Calculation Worksheets**
 - D-I Existing With Ambient Growth Year 2025 Without Project Traffic Conditions
 - D-II Existing With Ambient Growth Year 2025 With Project Traffic Conditions
- E. Existing With Ambient Growth Year 2025 With Cumulative With Project Traffic Conditions Intersection Level of Service Calculation Worksheets**
 - E-I Existing With Ambient Growth Year 2025 With Cumulative Without Project Traffic Conditions
 - E-II Existing With Ambient Growth Year 2025 With Cumulative With Project Traffic Conditions
 - E-III Existing With Ambient Growth Year 2025 With Cumulative With Project With Improvements Traffic Conditions
- F. Traffic Signal Warrant Worksheets**
 - F-I Existing With Ambient Growth Year 2025 With Cumulative Without Project Traffic Conditions
 - F-II Existing With Ambient Growth Year 2025 With Cumulative With Project Traffic Conditions
- G. Project Driveway Level of Service Calculation Worksheets**
 - G-I Existing With Project Traffic Conditions
 - G-II Existing With Ambient Growth Year 2025 With Project Traffic Conditions
 - G-III Existing With Ambient Growth Year 2025 With Cumulative With Project Traffic Conditions
- H. Drive-Through Queuing Study Data**

LIST OF FIGURES

SECTION – FIGURE #	FOLLOWING PAGE
1–1	Vicinity Map 3
2–1	Existing Site Aerial..... 4
2–2	Proposed Site Plan..... 4
3–1	Existing Roadway Conditions And Intersection Controls.....5
3–2	Existing AM Peak Hour Traffic Volumes..... 5
3–3	Existing PM Peak Hour Traffic Volumes 5
5–1	Project Trip Distribution Pattern.....11
5–2	AM Peak Hour Project Traffic Volumes..... 11
5–3	PM Peak Hour Traffic Project Volumes.....11
6–1	Existing With Project AM Peak Hour Traffic Volumes 15
6–2	Existing With Project PM Peak Hour Traffic Volumes 15
6–3	Location of Cumulative Projects..... 15
6–4	Cumulative Project Only AM Peak Hour Traffic Volumes..... 15
6–5	Cumulative Project Only PM Peak Hour Traffic Volumes..... 15
6–6	Year 2025 Existing With Ambient Growth Without Project AM Peak Hour Traffic Volumes 15
6–7	Year 2025 Existing With Ambient Growth Without Project PM Peak Hour Traffic Volumes..... 15
6–8	Year 2025 Existing With Ambient Growth With Project AM Peak Hour Traffic Volumes 15
6–9	Year 2025 Existing With Ambient Growth With Project PM Peak Hour Traffic Volumes 15
6–10	Year 2025 Existing With Ambient Growth With Cumulative Without Project AM Peak Hour Traffic Volumes 15
6–11	Year 2025 Existing With Ambient Growth With Cumulative Without Project PM Peak Hour Traffic Volumes..... 15

LIST OF FIGURES (CONTINUED)

SECTION – FIGURE #	FOLLOWING PAGE
6–12	Year 2025 Existing With Ambient Growth With Cumulative With Project AM Peak Hour Traffic Volumes 15
6–13	Year 2025 Existing With Ambient Growth With Cumulative With Project PM Peak Hour Traffic Volumes 15

LIST OF TABLES

SECTION-TABLE#	PAGE
3-1	Level of Service Criteria For Signalized Intersections (HCM 7 Methodology)..... 7
3-2	Level of Service Criteria For Unsignalized Intersections (HCM 7 Methodology) 8
5-1	Project Trip Generation Rates and Forecast 11
6-1	Location and Description of Cumulative Projects 14
6-2	Cumulative Projects Traffic Generation Forecast..... 15
7-1	Existing With Project Conditions Peak Hour Intersection Capacity Analysis Summary..... 17
8-1	Existing With Ambient Growth Year 2025 With Project Conditions Peak Hour Intersection Capacity Analysis Summary..... 19
9-1	Existing With Ambient Growth Year 2025 With Cumulative With Project Conditions Peak Hour Intersection Capacity Analysis Summary..... 21
10-1	Traffic Signal Warrant Analysis Summary..... 23
11-1	Project Driveway Peak Hour Levels of Service Summary 27
11-2	Project Driveway Queuing Analysis..... 28
11-3	Weekday (Thursday) Queuing Analysis Summary 29
11-4	Weekday (Friday) Queuing Analysis Summary 30
11-5	Weekend (Saturday) Queuing Analysis Summary 31
13-1	Existing With Ambient Growth With Cumulative With Project Traffic Conditions Fair Share Contribution..... 34

EXECUTIVE SUMMARY

Project Description

- The project site is currently vacant and is located on the northwest quadrant of Larch Avenue and Foothill Boulevard in the City of Rialto, California. The project applicant proposes to construct a 4,823 square foot (SF) Chick-fil-A restaurant with dual drive-through lanes (with drive-through queuing storage up to 40 vehicles). The Project is anticipated to be completed by the Year 2025. Access to the project site will be provided via one left-turn in/right-turn in/right-turn out only unsignalized driveway located along Foothill Boulevard (i.e. Project Driveway No. 1) and via one full access unsignalized driveway located along Larch Avenue (i.e. Project Driveway No. 2).

Project Trip Generation Forecast

- The proposed Project is forecast to generate 1,691 daily trips, with 161 trips (82 inbound, 79 outbound) produced in the AM peak hour and 119 trips (62 inbound, 57 outbound) produced in the PM peak hour on a “typical” weekday.

Key Intersections

- Four (4) key study intersections were selected for evaluation based on City criteria and discussions with City of Rialto staff. The key study intersections listed below provide local access to the study area and define the extent of the boundaries for this traffic impact investigation.
 1. Cedar Avenue at Foothill Boulevard
 2. Larch Avenue at Foothill Boulevard
 3. Spruce Avenue at Foothill Boulevard
 4. Cactus Avenue at Foothill Boulevard

Cumulative Projects Description

- The eleven (11) cumulative projects are forecast to generate a combined total of 13,988 daily trips, with 1,106 trips (621 inbound and 485 outbound) forecast during the AM peak hour and 1,048 trips (487 inbound and 561 outbound) forecast during the PM peak hour.

Traffic Impact Analysis

Existing Traffic Conditions

- Under Existing traffic conditions, the four (4) key study intersections currently operate at acceptable LOS D or better during the AM and PM peak hours.

Existing With Project Traffic Conditions

- The proposed Project **will not** impact the four (4) key study intersections when compared to the LOS standards and impact criteria specified in this report. The four (4) key study intersections currently operate and are forecast to continue to operate at an acceptable LOS during the AM and PM peak hours with the addition of Project generated traffic to existing traffic.

Existing With Ambient Growth (Year 2025) With Project Traffic Conditions

- The proposed Project **will not** impact the four (4) key study intersections when compared to the LOS standards and impact criteria specified in this report. The four (4) key study intersections are forecast to continue to operate at an acceptable LOS during the AM and PM peak hours with the addition of Project generated traffic to ambient traffic growth (Year 2025).

Existing With Ambient Growth (Year 2025) With Cumulative With Project Traffic Conditions

- The proposed Project will cumulatively impact one (1) of the four (4) key study intersections when compared to the LOS standards and impact criteria specified in this report. The remaining three (3) key study intersections are forecast to continue to operate at an acceptable LOS during the AM and PM peak hours with the addition of Project generated traffic to ambient traffic growth (Year 2025) and cumulative traffic. The location forecast to operate at an adverse LOS is as follows:

<u>Key Intersection</u>	<u>AM Peak Hour</u>		<u>PM Peak Hour</u>	
	<u>Delay (s/v)</u>	<u>LOS</u>	<u>Delay (s/v)</u>	<u>LOS</u>
2. Larch Avenue at Foothill Boulevard	50.7 s/v	F	41.3 s/v	E

Although the intersection of Larch Avenue at Foothill Boulevard is forecasted to operate at a deficient level of service, it is our understanding that a traffic signal is planned at this location. The implementation of a traffic signal at this intersection will improve this deficiency and the intersection is forecast to operate at an acceptable level of service during the AM peak hour and PM peak hour.

Traffic Signal Warrant Analysis

Existing With Ambient Growth (Year 2025) With Cumulative Without Project Traffic Conditions

- The results of the peak-hour traffic signal warrant analysis for Existing With Ambient Growth (Year 2025) With Cumulative Without Project traffic conditions indicate that the intersection of Larch Avenue at Foothill Boulevard has future traffic conditions that would exceed the volume thresholds of Warrant #3, Part B for the AM peak hour. Thus, a traffic signal is recommended at this location.

Existing With Ambient Growth (Year 2025) With Cumulative With Project Traffic Conditions

- The results of the peak-hour traffic signal warrant analysis for the Existing With Ambient Growth (Year 2025) With Cumulative With Project traffic conditions indicate that the intersection of Larch Avenue at Foothill Boulevard has future traffic conditions that would exceed the volume thresholds of Warrant #3, Part B for the AM and PM peak hours. Thus, a traffic signal is recommended at this location.

Site Access and Internal Circulation Evaluation

- The two (2) proposed project driveways are forecast to operate at acceptable LOS B or better during the AM and PM peak hours for all scenarios.
- Adequate storage is provided for Project Driveway No. 1 (i.e. southbound right-turn lane and eastbound left-turn lane) and for Project Driveway No. 2 (i.e. eastbound left-turn/right-turn lane) during the AM and PM peak hours for Existing With Ambient Growth (Year 2025) With Cumulative With Project traffic conditions.
- The on-site circulation layout of the proposed Project as illustrated in *Figure 2-2* on an overall basis is adequate. Curb return radii are generally adequate for small service/delivery (FedEx, UPS) trucks, trash trucks and fire trucks.
- Based on existing drive-through queuing observations, adequate storage is provided for the Chick-fil-A drive-through lane and vehicles are not anticipated to queue back onto Foothill Boulevard or Larch Avenue. Refer to Section 11.3 for further details regarding the Drive-Through Queuing Analysis, including Chick-fil-A's drive-through operations plan.

Project-Specific Improvements

- The following project design feature will be constructed by the proposed Project.
 - Intersection 2. Larch Avenue at Foothill Boulevard: Restripe the westbound right-turn lane on Foothill Boulevard to a westbound shared through/right-turn lane.

Recommended Improvements

Existing With Project Traffic Conditions

- The results of the Existing With Project traffic conditions level of service analyses indicate that the proposed Project ***will not*** impact any of the four (4) key study intersections. The four (4) key study intersections are forecast to operate at acceptable service levels under Existing With Project traffic conditions. As such, no improvement measures addressing LOS have been recommended.

Existing With Ambient Growth (Year 2025) With Project Traffic Conditions

- The results of the Existing With Ambient Growth (Year 2025) With Project traffic conditions level of service analyses indicate that the proposed Project ***will not*** impact any of the four (4) key study intersections. The four (4) key study intersections are forecast to operate at acceptable service levels under Existing With Ambient Growth (Year 2025) With Project traffic conditions. As such, no improvement measures addressing LOS have been recommended.

Existing With Ambient Growth (Year 2025) With Cumulative With Project Traffic Conditions

- The results of the Existing With Ambient Growth (Year 2025) With Cumulative With Project traffic conditions level of service analyses indicate that the proposed Project will impact one (1) of the four (4) key study intersections. The following improvements listed below have been identified to offset the effect of ambient, cumulative, and Project traffic, and improve levels of service to an acceptable range:
 - **Intersection 2. Larch Avenue at Foothill Boulevard:** Install a traffic signal and design for five-phase operation with protected left-turn phasing on Foothill Boulevard. Implement all necessary signing and striping improvements, inclusive of crosswalks for all legs of the intersection.

Project Fair Share Analysis

- The Project fair share percentage (most adverse time period) for the deficient intersection for Existing With Ambient Growth With Cumulative With Project traffic conditions that require recommended improvements are shown below:
 - 2. Larch Avenue at Foothill Boulevard 29.75%

Vehicle Miles Traveled (VMT) Assessment

- The proposed Project will consist of a local serving 4,823 SF Chick-fil-A restaurant with drive-through window. Therefore, based on Project Screening – Step 3: Project Type Screening (i.e. local-serving retail projects less than 50,000 square feet), this project would screen out from a VMT analysis and be presumed to have a less than significant impact on VMT, per the City’s guidelines.

TRAFFIC IMPACT ANALYSIS REPORT

FOOTHILL AND LARCH CHICK-FIL-A PROJECT

Rialto, California
August 3, 2023

1.0 INTRODUCTION

This traffic impact analysis addresses the potential traffic impacts and circulation needs associated with the Foothill and Larch Chick-fil-A Project (hereinafter referred to as Project). The project site is currently vacant and is located on the northwest quadrant of Larch Avenue and Foothill Boulevard in the City of Rialto, California. The project applicant proposes to construct a 4,823 square-foot (SF) Chick-fil-A restaurant with dual drive-through lanes (with drive-through queuing storage up to 40 vehicles).

This traffic report documents the findings and recommendations of a traffic impact analysis conducted by Linscott, Law & Greenspan, Engineers (LLG) to determine the potential impacts associated with the proposed Project. The traffic analysis evaluates the operating conditions at four (4) key study intersections within the project vicinity, estimates the trip generation potential of the proposed Project, and forecasts future operating conditions without and with the proposed Project. Where necessary, intersection improvements/mitigation measures are identified.

This traffic report satisfies the *City of Rialto Traffic Impact Analysis Guidelines for Vehicle Miles Traveled (VMT) and Level of Service Assessment (LOS)*, dated October 2021. The Scope of Work for this traffic study, which is included in **Appendix A**, was developed in conjunction with City of Rialto staff.

The project site has been visited and an inventory of adjacent area roadways and intersections was performed. Existing traffic information has been collected at four (4) key study intersections on a “typical” weekday for use in the preparation of intersection level of service calculations. Information concerning cumulative projects (planned and/or approved) in the vicinity of the proposed Project has been researched at the City of Rialto and the City of Fontana. Based on our research, there are six (6) cumulative projects located in the City of Rialto and five (5) cumulative projects located in the City of Fontana within the vicinity of the subject site. These eleven (11) planned and/or approved cumulative projects were considered in the cumulative traffic analysis for this project.

This traffic report analyzes existing and future weekday AM peak hour and PM peak hour traffic conditions for a near-term (Year 2025) traffic setting upon completion of the proposed Project. Peak hour traffic forecasts for the Year 2025 horizon year have been projected by increasing existing traffic volumes by an annual growth rate of 2.0% per year and adding traffic volumes generated by eleven (11) cumulative projects, which provides a conservative forecast.

1.1 Study Area

The four (4) key study intersections were selected for evaluation based on City criteria and discussions with City of Rialto staff. The key study intersections listed below provide local access to the study area and define the extent of the boundaries for this traffic impact investigation.

5. Cedar Avenue at Foothill Boulevard
6. Larch Avenue at Foothill Boulevard
7. Spruce Avenue at Foothill Boulevard
8. Cactus Avenue at Foothill Boulevard

1.2 Traffic Impact Analysis Components

The Highway Capacity Manual (HCM) Delay and corresponding Level of Service (LOS) calculations at the key study locations were used to evaluate the potential traffic-related impacts associated with area growth, cumulative traffic and the proposed Project. When necessary, this report recommends intersection improvements that may be required to accommodate future traffic volumes and restore/maintain an acceptable Level of Service and/or addresses the impact of the proposed Project. Included in this Traffic Impact Analysis are:

- Existing traffic counts,
- Estimated Project traffic generation/distribution/assignment,
- Estimated cumulative project traffic generation/distribution/assignment,
- AM and PM peak hour LOS analyses for Existing (Year 2023) conditions,
- AM and PM peak hour LOS analyses for Existing conditions with Project traffic,
- AM and PM peak hour LOS analyses for Existing with Ambient Growth (Year 2025) without Project traffic,
- AM and PM peak hour LOS analyses for Existing with Ambient Growth (Year 2025) with Project traffic,
- AM and PM peak hour LOS analyses for Existing with Ambient Growth (Year 2025) with Cumulative traffic conditions without Project traffic,
- AM and PM peak hour LOS analyses for Existing with Ambient Growth (Year 2025) with Cumulative traffic conditions with Project traffic,
- Site Access and On-Site Circulation Analysis,
- Recommended Improvements, and
- Vehicle Miles Traveled (VMT) Assessment.

Figure 1-1 presents a Vicinity Map, which illustrates the general location of the Project and depicts the study locations and surrounding street system.

1.3 Traffic Impact Analysis Scenarios

The following scenarios are those for which Delay and corresponding LOS calculations have been performed at the key study intersections for existing and near-term traffic conditions:

1. Existing (Year 2023) Traffic Conditions
2. Existing With Project Traffic Conditions,
3. Scenario (2) With Recommended Improvements, if any,
4. Existing With Ambient Growth (Year 2025) Without Project Traffic Conditions,
5. Existing With Ambient Growth (Year 2025) With Project Traffic Conditions,
6. Scenario (5) With Recommended Improvements, if any,
7. Existing With Ambient Growth (Year 2025) With Cumulative Without Project Traffic Conditions,
8. Existing With Ambient Growth (Year 2025) With Cumulative With Project Traffic Conditions, and
9. Scenario (8) With Recommended Improvements, if any.

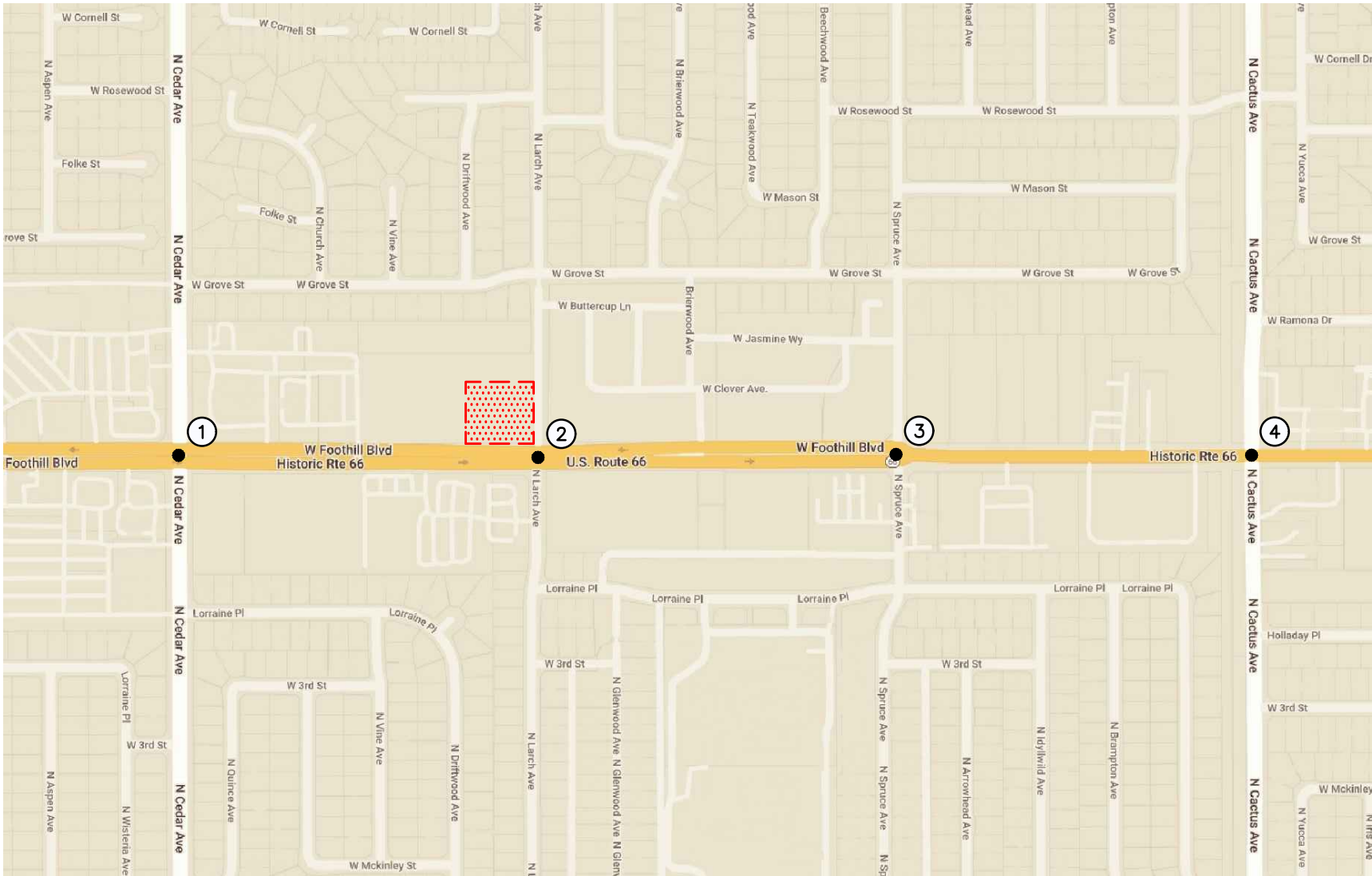

n:\4600\2234640 - foothill and larch chick-fil-a project_rialto\dwg\4640_f1-1.dwg LDP 11-24-08 01-30-2023 aguilera



SOURCE: GOOGLE

KEY

= STUDY INTERSECTION

[Red hatched box] = PROJECT SITE

FIGURE 1-1

VICINITY MAP

FOOTHILL AND LARCH CHICK-FIL-A, RIALTO

2.0 PROJECT DESCRIPTION AND LOCATION

The project site is currently vacant and is located on the northwest quadrant of Larch Avenue and Foothill Boulevard in the City of Rialto, California. The project applicant proposes to construct a 4,823 SF Chick-fil-A restaurant with dual drive-through lanes (with drive-through queuing storage up to 40 vehicles). The Project is anticipated to be completed by the Year 2025.

Figure 2-1 presents an aerial image of the existing site for the proposed Project. *Figure 2-2* presents the site plan for the proposed Project.

2.1 Site Access

Access to the project site will be provided via one left-turn in/right-turn in/right-turn out only unsignalized driveway located along Foothill Boulevard (i.e. Project Driveway No. 1) and via one full access unsignalized driveway located along Larch Avenue (i.e. Project Driveway No. 2).

2.2 Project-Specific Improvements

The following project design feature will be constructed by the proposed Project.

- Intersection 2. Larch Avenue at Foothill Boulevard: Restripe the westbound right-turn lane on Foothill Boulevard to a westbound shared through/right-turn lane.



n:\4600\2234640 - foothill and larch chick-fil-a project, rialto\dwg\4640 f2-1.dwg LDP 14:21:07 01-30-2023 aguilera

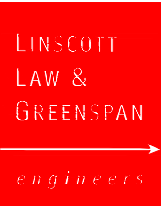

SOURCE: GOOGLE

KEY

 = PROJECT SITE

FIGURE 2-1

EXISTING SITE AERIAL
FOOTHILL AND LARCH CHICK-FIL-A, RIALTO

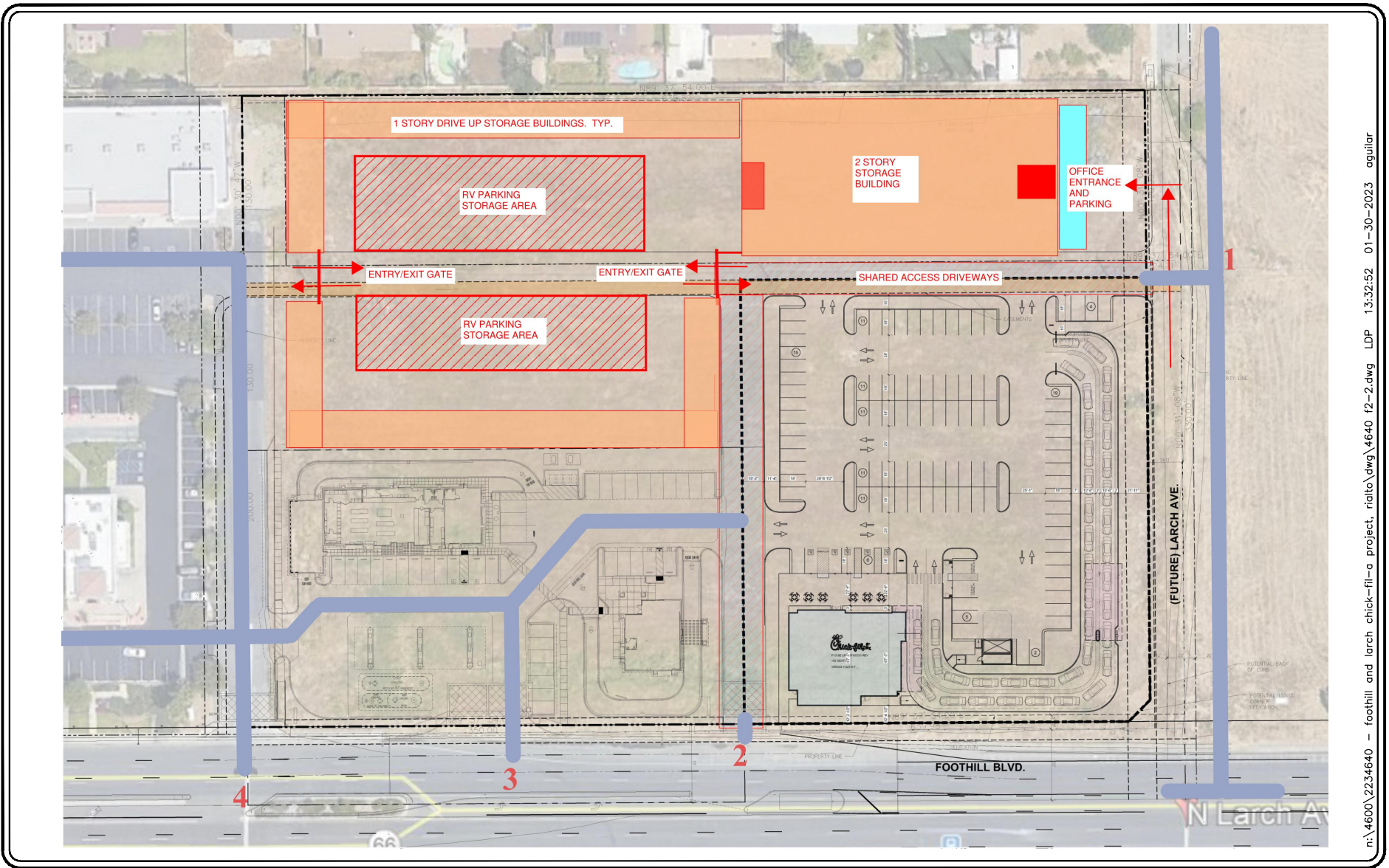

n:\4600\2234640 - foothill and larch chick-fil-a project, rialto\dwg\4640 f2-2.dwg LDP 13:32:52 01-30-2023 agular

SOURCE: CRHO ARCHITECTS

FIGURE 2-2

LINSCOTT
LAW &
GREENSPAN
engineers

NO SCALE

PROPOSED SITE PLAN
FOOTHILL AND LARCH CHICK-FIL-A, RIALTO

3.0 ANALYSIS CONDITIONS AND METHODOLOGY

3.1 Existing Street Network

The principal local network of streets serving the Project site consists of Foothill Boulevard and Larch Avenue. The following discussion provides a brief synopsis of the key area streets.

Foothill Boulevard is generally a six-lane divided roadway west of Larch Avenue and generally a five-lane divided roadway east of Larch Avenue. Foothill Boulevard is oriented in the east-west direction and borders the project site to the south. On-street parking is generally not permitted on either side of the roadway. The posted speed limit on Foothill Boulevard is 50 miles per hour (mph) west of Spruce Avenue and 45 mph east of Spruce Avenue. A traffic signal controls the study intersections of Foothill Boulevard at Cedar Avenue, Spruce Avenue, and Cactus Avenue. The intersection of Foothill Boulevard at Larch Avenue is currently stop controlled.

Larch Avenue is a two-lane undivided roadway, oriented in the north-south direction, which borders the project site to the east. On-street parking is permitted on either side of the roadway in the vicinity of the project site. The prima facie speed limit on Larch Avenue is 25 mph. The intersection of Larch Avenue at Foothill Boulevard is currently stop controlled.

Figure 3-1 presents an inventory of the existing roadway conditions within the study area evaluated in this report. The number of travel lanes and intersection controls for the key area study intersections are identified.

3.2 Existing Traffic Volumes

Four (4) key study intersections have been identified as the locations at which to evaluate existing and future traffic operating conditions. Some portion of potential Project-related traffic will pass through these intersections and the analysis will reveal the expected relative impacts of the Project. The key study intersections were selected for evaluation based on discussions with City of Rialto staff.

Existing AM and PM peak hour traffic volumes for the four (4) key study intersections evaluated in this report were obtained from manual peak hour turning movement counts conducted by *Counts Unlimited, Inc.* on May 16, 2023 when local area schools were in session. *Figures 3-2* and *3-3* illustrate the existing AM and PM peak hour traffic volumes at the four (4) key study intersections evaluated in this report, respectively. *Appendix B* contains the detailed peak hour traffic count sheets for the key intersections evaluated in this report.

3.3 Level Of Service (LOS) Analysis Methodologies

AM and PM peak hour operating conditions for the signalized and unsignalized intersections and unsignalized driveways were evaluated using the *Highway Capacity Manual 7* (HCM 7) methodology.

Per the City of Rialto traffic impact analysis guidelines, the existing peak hour factor has been utilized for the Existing analysis scenario. In addition, the existing peak hour factor has also been

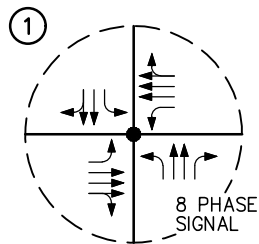
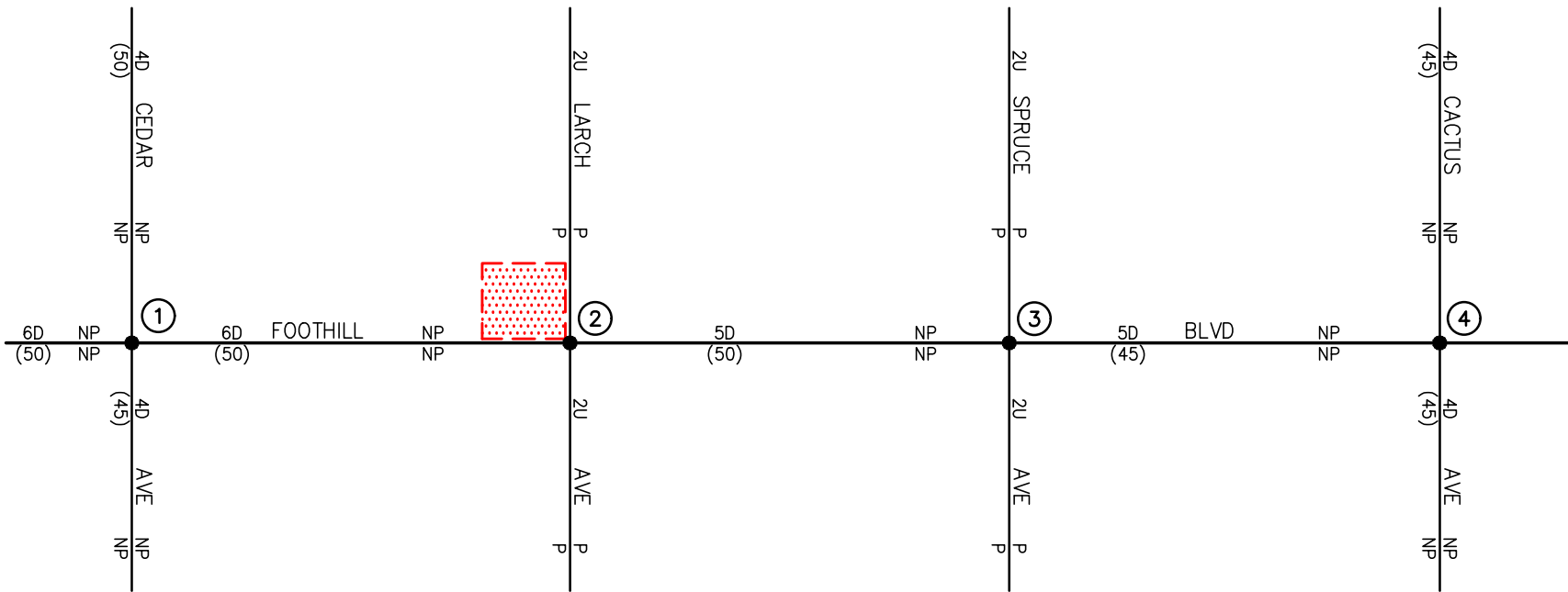

1 CEDAR AVE @
FOOTHILL BLVD

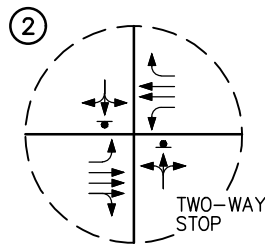

2 LARCH AVE @
FOOTHILL BLVD

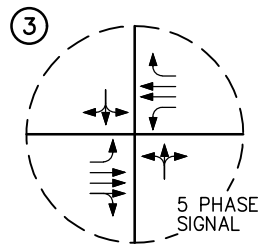

3 SPRUCE AVE @
FOOTHILL BLVD

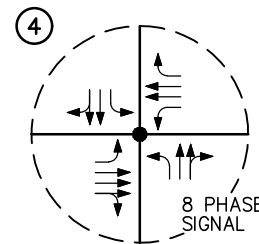

4 CACTUS AVE @
FOOTHILL BLVD

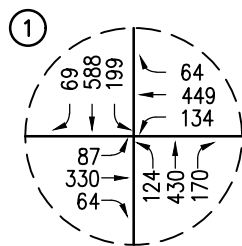
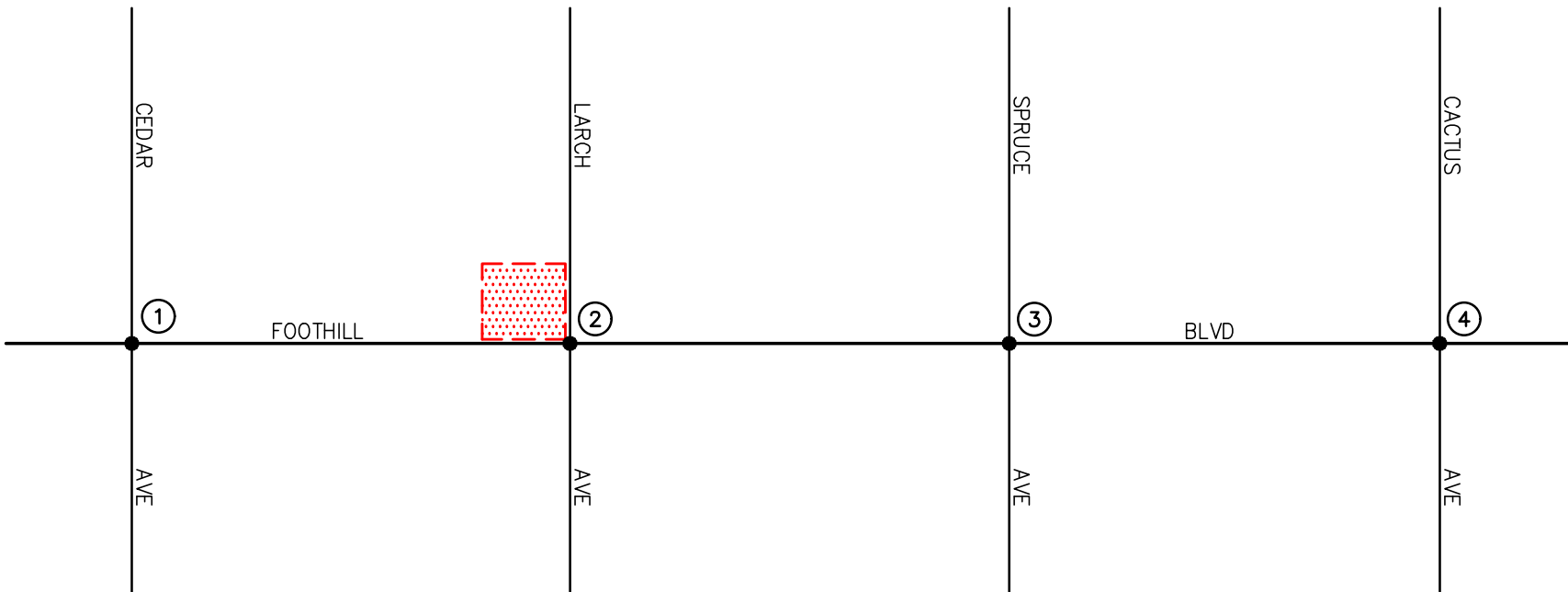

1 CEDAR AVE @
FOOTHILL BLVD

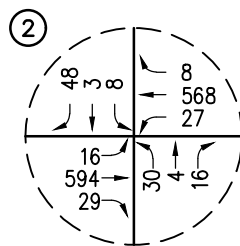

2 LARCH AVE @
FOOTHILL BLVD

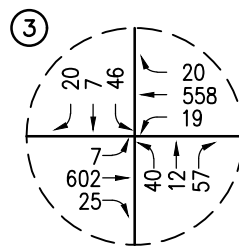

3 SPRUCE AVE @
FOOTHILL BLVD

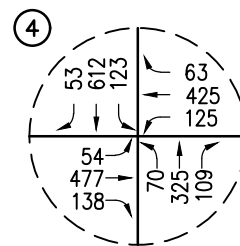

4 CACTUS AVE @
FOOTHILL BLVD

n:\4600\2234640 - foothill and larch chick-fil-a project, rialto\dwg\4640 f3-2.dwg LDP 15:09:23 06-27-2023 aguilera



KEY
 # = STUDY INTERSECTION
 [Red Hatched Box] = PROJECT SITE

FIGURE 3-2

EXISTING AM PEAK HOUR TRAFFIC VOLUMES
 FOOTHILL AND LARCH CHICK-FIL-A, RIALTO

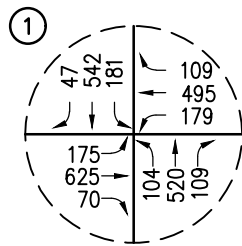
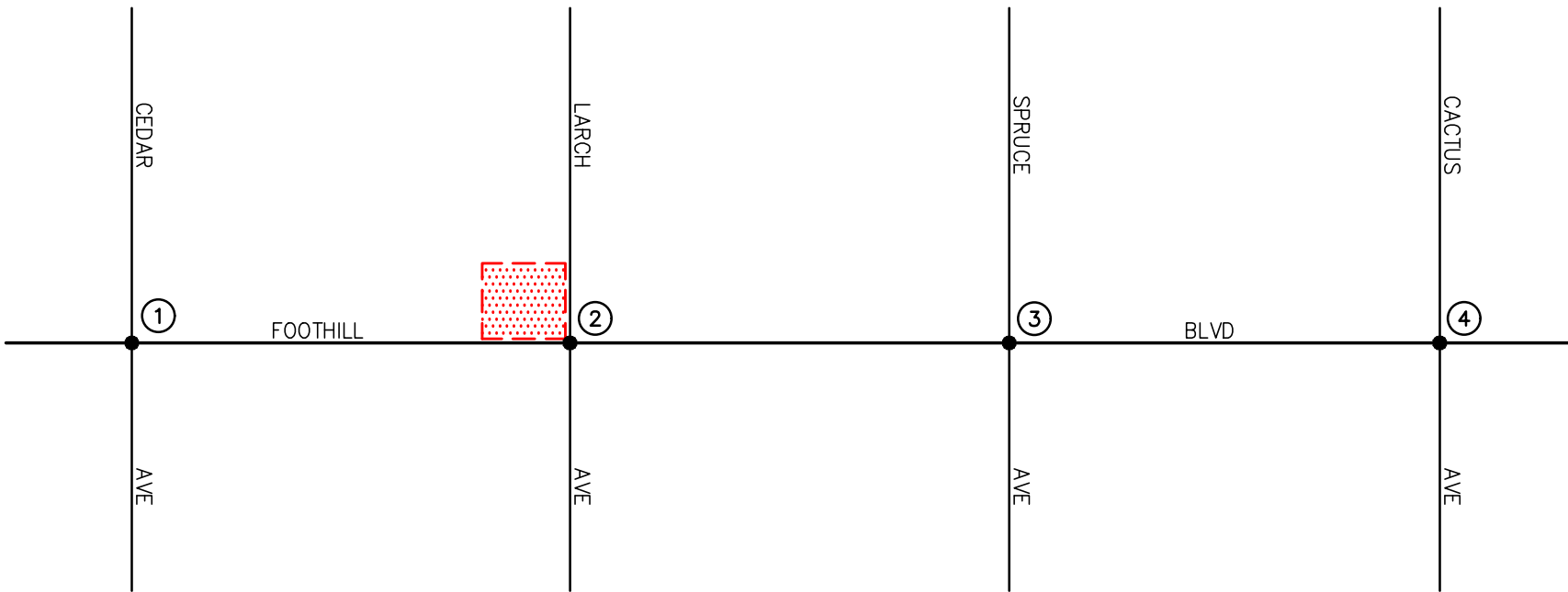

CEDAR AVE @
FOOTHILL BLVD

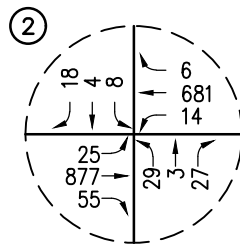

LARCH AVE @
FOOTHILL BLVD

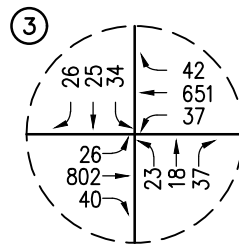

SPRUCE AVE @
FOOTHILL BLVD

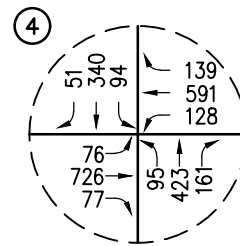

CACTUS AVE @
FOOTHILL BLVD

n:\4600\2234640 - foothill and larch chick-fil-a project, rialto\dwg\4640 f3-3.dwg LDP 15:10:53 06-27-2023 aguilera

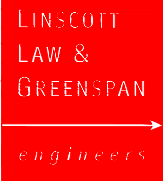

KEY

= STUDY INTERSECTION

[Red hatched box] = PROJECT SITE

FIGURE 3-3

EXISTING PM PEAK HOUR TRAFFIC VOLUMES
FOOTHILL AND LARCH CHICK-FIL-A, RIALTO

utilized for the Existing With Ambient Growth With Project and the Existing With Ambient Growth With Cumulative With Project analysis scenarios

3.3.1 Highway Capacity Manual 7 (HCM 7) Method of Analysis (Signalized Intersections)

Based on the HCM operations method of analysis, level of service for signalized intersections and approaches is defined in terms of control delay, which is a measure of the increase in travel time due to traffic signal control, driver discomfort, and fuel consumption. Control delay includes the delay associated with vehicles slowing in advance of an intersection, the time spent stopped on an intersection approach, the time spent as vehicles move up in the queue, and the time needed for vehicles to accelerate to their desired speed. LOS criteria for traffic signals are stated in terms of the control delay in seconds per vehicle. The LOS thresholds established for the automobile mode at a signalized intersection are shown in *Table 3-1*.

3.3.2 Highway Capacity Manual 7 (HCM 7) Method of Analysis (Unsignalized Intersections)

The HCM unsignalized methodology for stop-controlled intersections was utilized for the analysis of the unsignalized intersections. This methodology estimates the average control delay for each of the subject movements and determines the level of service for each movement. For all-way stop controlled intersections, the overall average control delay measured in seconds per vehicle, and level of service is calculated for the entire intersection. For one-way and two-way stop-controlled (minor street stop-controlled) intersections, this methodology estimates the worst side street delay, measured in seconds per vehicle and determines the level of service for that approach. The HCM control delay value translates to a Level of Service (LOS) estimate, which is a relative measure of the intersection performance. The six qualitative categories of Level of Service have been defined along with the corresponding HCM control delay value range, as shown in *Table 3-2*.

3.4 Impact Criteria and Thresholds

According to City of Rialto criteria, LOS D is the minimum acceptable condition that should be maintained during the morning and evening peak commute hours for intersections.

Project related impacts are identified by comparing without Project conditions to with Project conditions based on the following criteria:

- If the LOS deteriorates from an acceptable LOS D or better to an unacceptable LOS E or F; or
- If the proposed Project increases the intersection delay as detailed below:
 - LOS A/B = Delay increases by 10.0 seconds or more
 - LOS C = Delay increases by 8.0 seconds or more
 - LOS D = Delay increases by 5.0 seconds or more
 - LOS E = Delay increases by 2.0 seconds or more
 - LOS F = Delay increases by 1.0 second or more

TABLE 3-1
LEVEL OF SERVICE CRITERIA FOR SIGNALIZED INTERSECTIONS (HCM 7 METHODOLOGY)¹

Level of Service (LOS)	Control Delay Per Vehicle (seconds/vehicle)	Level of Service Description
A	≤ 10.0	This level of service occurs when progression is extremely favorable and most vehicles arrive during the green phase. Most vehicles do not stop at all. Short cycle lengths may also contribute to low delay.
B	> 10.0 and ≤ 20.0	This level generally occurs with good progression, short cycle lengths, or both. More vehicles stop than with LOS A, causing higher levels of average delay.
C	> 20.0 and ≤ 35.0	Average traffic delays. These higher delays may result from fair progression, longer cycle lengths, or both. Individual cycle failures may begin to appear at this level. The number of vehicles stopping is significant at this level, though many still pass through the intersection without stopping.
D	> 35.0 and ≤ 55.0	Long traffic delays At level D, the influence of congestion becomes more noticeable. Longer delays may result from some combination of unfavorable progression, long cycle lengths, or high v/c ratios. Many vehicles stop and the proportion of vehicles not stopping declines. Individual cycle failures are noticeable.
E	> 55.0 and ≤ 80.0	Very long traffic delays This level is considered by many agencies to be the limit of acceptable delay. These high delay values generally indicate poor progression, long cycle lengths and high v/c ratios. Individual cycle failures are frequent occurrences.
F	≥ 80.0	Severe congestion This level, considered to be unacceptable to most drivers, often occurs with over saturation, that is, when arrival flow rates exceed the capacity of the intersection. It may also occur at high v/c ratios below 1.0 with many individual cycle failures. Poor progression and long cycle lengths may also be major contributing factors to such delay levels.

¹ Source: *Highway Capacity Manual 7*, Chapter 19: Signalized Intersections.

TABLE 3-2

LEVEL OF SERVICE CRITERIA FOR UNSIGNALIZED INTERSECTIONS (HCM 7 METHODOLOGY)^{2,3}

Level of Service (LOS)	Highway Capacity Manual (HCM) Delay Per Vehicle (seconds/vehicle)	Level of Service Description
A	≤ 10.0	Little or no delay
B	> 10.0 and ≤ 15.0	Short traffic delays
C	> 15.0 and ≤ 25.0	Average traffic delays
D	> 25.0 and ≤ 35.0	Long traffic delays
E	> 35.0 and ≤ 50.0	Very long traffic delays
F	> 50.0	Severe congestion

² Source: *Highway Capacity Manual 7*, Chapter 20: Two-Way Stop-Controlled Intersections. The LOS criteria apply to each lane on a given approach and to each approach on the minor street. LOS is not calculated for major-street approaches or for the intersection as a whole.

³ Source: *Highway Capacity Manual 7*, Chapter 21: All-Way Stop-Controlled Intersections. For approaches and intersection-wide assessment, LOS is defined solely by control delay.

4.0 TRAFFIC FORECASTING METHODOLOGY

In order to estimate the traffic impact characteristics of the Project, a multi-step process has been utilized. The first step is traffic generation, which estimates the total arriving and departing traffic on a peak hour and daily basis. The traffic generation potential is forecast by applying the appropriate vehicle trip generation equations and/or rates to the Project development tabulation.

The second step of the forecasting process is traffic distribution, which identifies the origins and destinations of inbound and outbound Project traffic. These origins and destinations are typically based on demographics and existing/expected future travel patterns in the study area.

The third step is traffic assignment, which involves the allocation of Project traffic to study area streets and intersections. Traffic assignment is typically based on minimization of travel time, which may or may not involve the shortest route, depending on prevailing operating conditions and travel speeds.

Traffic distribution patterns are indicated by general percentage orientation, while traffic assignment allocates specific volume forecasts to individual roadway segments and intersection turning movements throughout the study area.

With the forecasting process complete and Project traffic assignments developed, the impact of the Project is isolated by comparing operational (LOS) conditions at selected key intersections using expected future traffic volumes with and without forecast Project traffic. If necessary, the need for site-specific and/or cumulative local area traffic improvements can then be evaluated.

5.0 PROJECT TRAFFIC CHARACTERISTICS

5.1 Project Trip Generation Forecast

Trip generation is expressed in vehicle trip ends, defined as one-way vehicular movements, either entering or exiting the generating land use. Generation equations and/or rates used in the traffic forecasting procedure are found in the 11th Edition of *Trip Generation*, published by the Institute of Transportation Engineers (ITE) [Washington D.C., 2021].

Table 5-1 summarizes the trip generation rates used in forecasting the vehicular trips generated by the proposed Project and presents the forecast daily and peak hour project traffic volumes for a “typical” weekday. As shown in the upper portion of *Table 5-1*, the trip generation potential for the proposed Project was forecast using ITE Land Use Code 934: Fast-Food Restaurant with Drive-Through Window trip rates.

A review of the last row of *Table 5-1* indicates that the proposed Project is forecast to generate 1,691 daily trips, with 161 trips (82 inbound, 79 outbound) produced in the AM peak hour and 119 trips (62 inbound, 57 outbound) produced in the PM peak hour on a “typical” weekday. It should be noted that the aforementioned overall trip generation includes adjustments for pass-by per the *Trip Generation Handbook, 11th Edition*, published by ITE, to account for trips that are already in the everyday traffic stream on the adjoining streets (i.e. Foothill Boulevard and Larch Avenue) and will stop as they pass by the Project site as a matter of convenience on their path to another destination. The pass-by reduction factors utilized are summarized in the footnotes of *Table 5-1*. It should also be noted that the trip generation methodology and forecasts were approved by City of Rialto staff prior to proceeding with further analysis.

5.2 Project Traffic Distribution and Assignment

Figure 5-1 illustrates the directional traffic distribution pattern for the proposed Project. Project traffic volumes both entering and exiting the project site have been distributed and assigned to the adjacent street system based on the following considerations:

- the site's proximity to major traffic carriers,
- expected localized traffic flow patterns based on adjacent street channelization and presence of traffic signals, and
- ingress/egress availability at the project site.

It should be noted that the Project trip distribution pattern was submitted to City staff for their review and approval prior to proceeding with further analyses.

The anticipated AM and PM peak hour project traffic volumes associated with the proposed Project are presented in *Figures 5-2* and *5-3*, respectively. The traffic volume assignments presented in *Figures 5-2* and *5-3* reflect the traffic distribution characteristics shown in *Figure 5-1* and the traffic generation forecast presented in *Table 5-1*.

TABLE 5-1
PROJECT TRIP GENERATION RATES AND FORECAST⁴

ITE Land Use Code / Project Description	Daily 2-Way	AM Peak Hour			PM Peak Hour		
		Enter	Exit	Total	Enter	Exit	Total
<u>Generation Rates:</u>							
▪ 934: Fast-Food Restaurant With Drive-Thru Window (TE/TSF)	467.48	51%	49%	44.61	52%	48%	33.03
<u>Proposed Project Generation Forecast</u>							
▪ Chick-fil-A with Drive-Thru Window (4.823 TSF)	2,255	110	105	215	83	76	159
Pass-By (Daily: 25%, AM: 25%, PM: 25%) ⁵	<u>-564</u>	<u>-28</u>	<u>-26</u>	<u>-54</u>	<u>-21</u>	<u>-19</u>	<u>-40</u>
<i>Subtotal</i>	<i>1,691</i>	<i>82</i>	<i>79</i>	<i>161</i>	<i>62</i>	<i>57</i>	<i>119</i>
Total Net Trip Generation Forecast	1,691	82	79	161	62	57	119

Notes:

- TE/TSF = Trip End per Thousand Square Feet

⁴ Source: *Trip Generation, 11th Edition*, Institute of Transportation Engineers, (ITE) [Washington, D.C. (2021)].

⁵ Source: *Trip Generation Handbook, 11th Edition*, Institute of Transportation Engineers, (ITE) [Washington, D.C. (2021)]. Pass-by reductions for fast-food restaurant with drive-through window consist of the following: 25% daily (estimated), 50% AM and 55% PM. However, according to City of Rialto Guidelines, pass-by trip reductions cannot exceed 25%. Therefore, a pass-by reduction of 25% has been assumed for the Daily, AM peak hour, and PM peak hour.

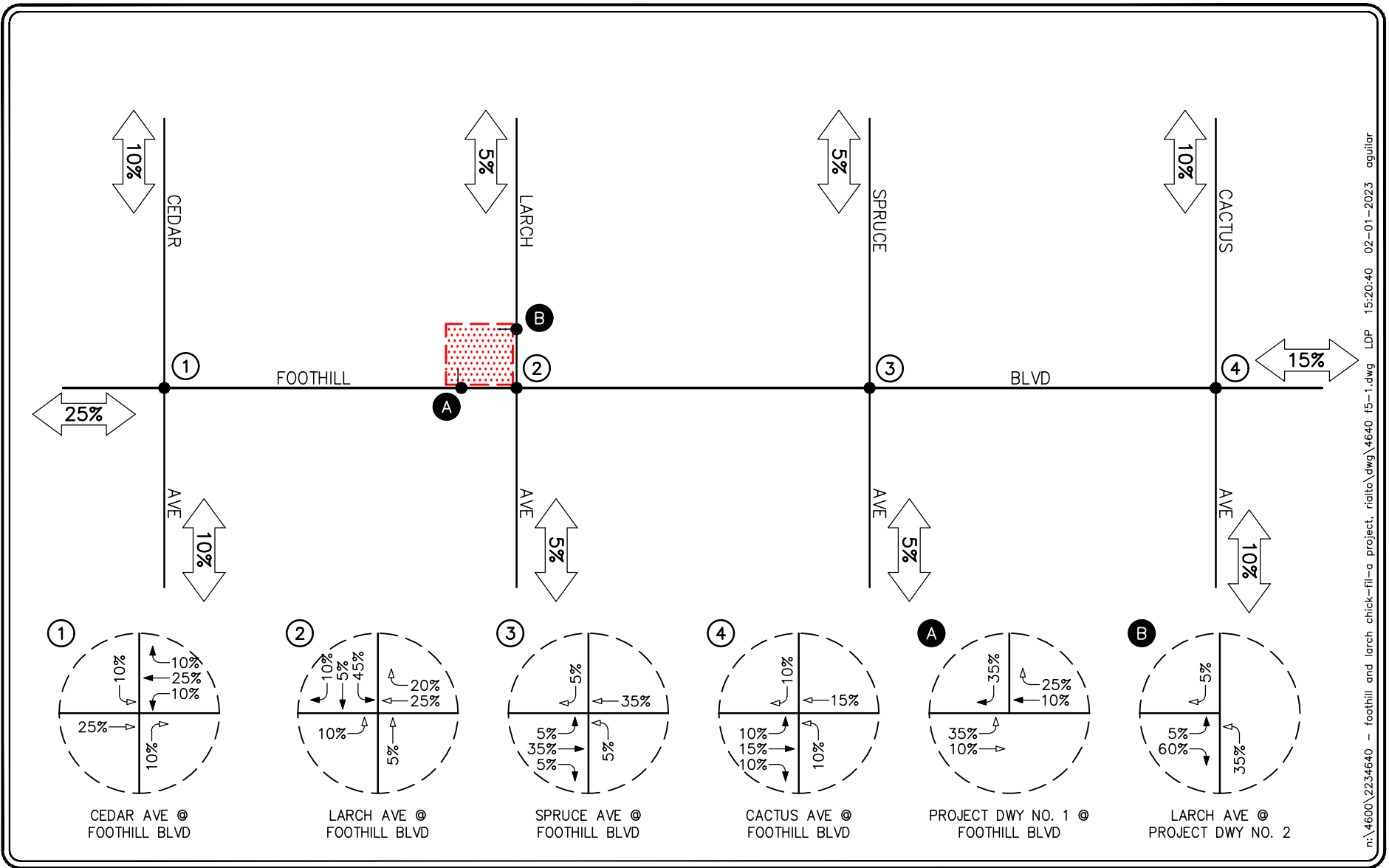

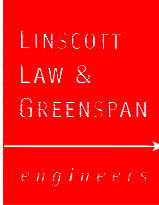



NO SCALE

KEY

- # = STUDY INTERSECTION
- ← = INBOUND PERCENTAGE
- = OUTBOUND PERCENTAGE
-  = PROJECT SITE

FIGURE 5-1

PROJECT TRIP DISTRIBUTION PATTERN

FOOTHILL AND LARCH CHICK-FIL-A, RIALTO

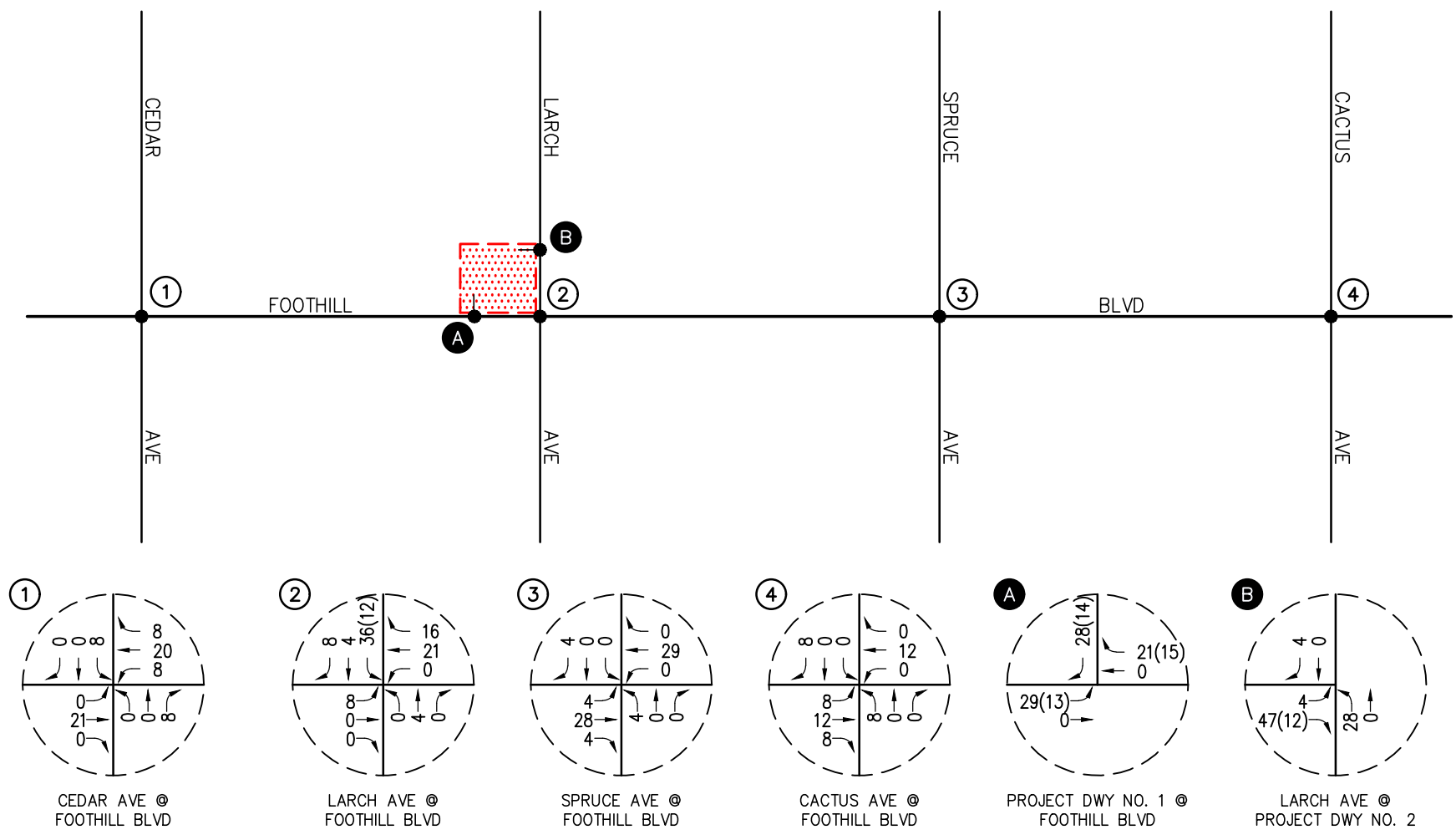

**LINSCOTT
LAW &
GREENSPAN**
engineers

NO SCALE

- KEY**
- ① = STUDY INTERSECTION
 - ▨ = PROJECT SITE
 - (XX) = PASS-BY TRIPS

FIGURE 5-2

AM PEAK HOUR PROJECT TRAFFIC VOLUMES
FOOTHILL AND LARCH CHICK-FIL-A, RIALTO

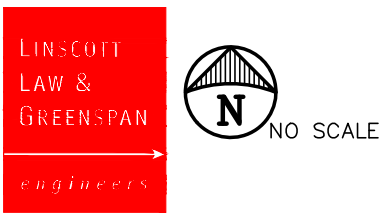
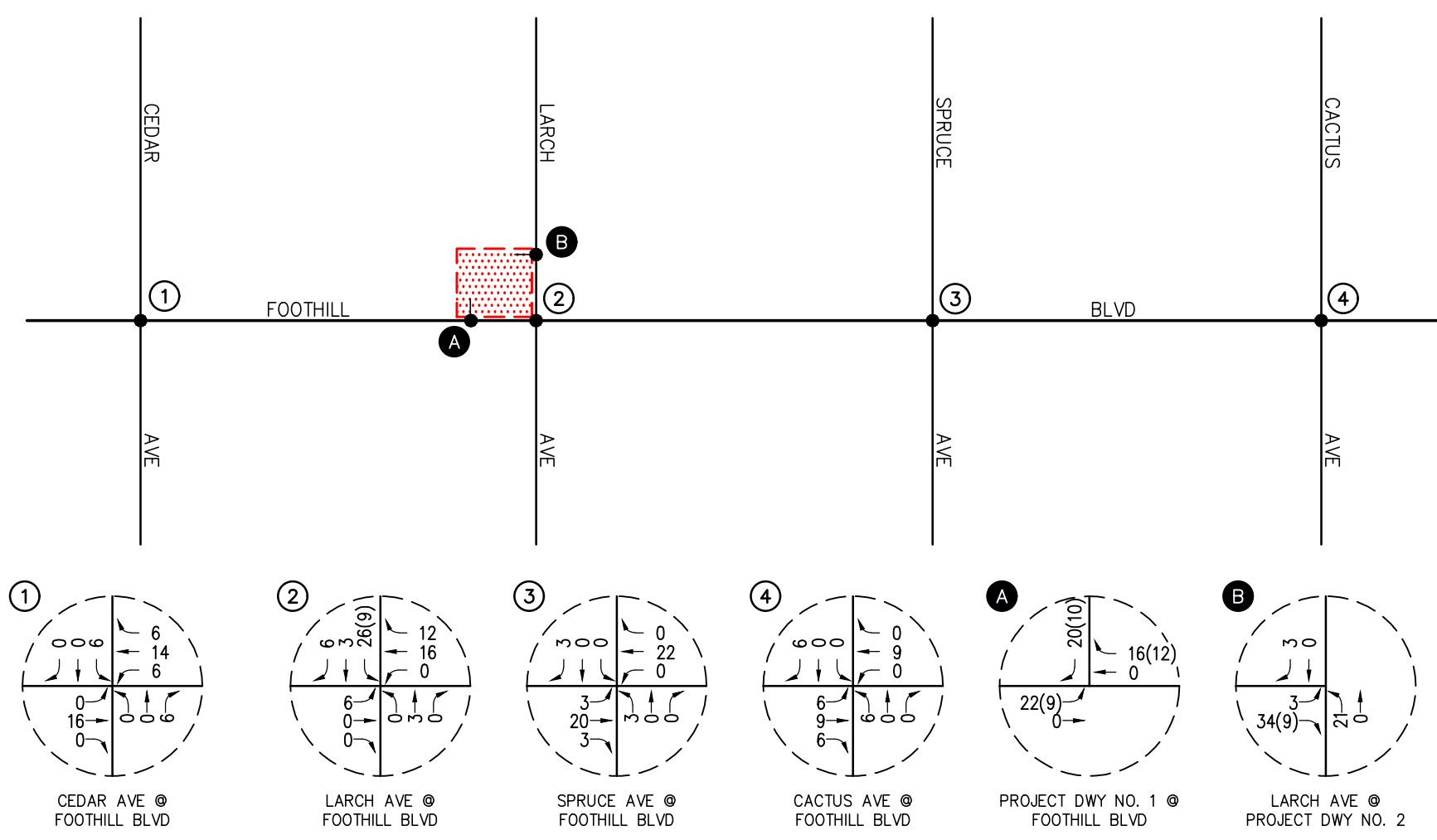

KEY

- ① = STUDY INTERSECTION
- ▨ = PROJECT SITE
- (XX) = PASS-BY TRIPS

FIGURE 5-3

PM PEAK HOUR PROJECT TRAFFIC VOLUMES
FOOTHILL AND LARCH CHICK-FIL-A, RIALTO

6.0 FUTURE TRAFFIC CONDITIONS

6.1 Existing With Project Traffic Volumes

The estimates of Project generated traffic volumes were added to Existing traffic conditions to develop traffic projections for Existing With Project traffic conditions. *Figures 6-1* and *6-2* present the anticipated AM and PM peak hour Existing With Project traffic volumes, respectively at the four (4) key study intersections.

6.2 Year 2025 With Project Traffic Volumes

6.2.1 Ambient Traffic Growth

Horizon year, background traffic growth estimates have been calculated using an ambient growth factor. The ambient traffic growth factor is intended to include unknown and future cumulative projects in the study area, as well as account for regular growth in traffic volumes due to the development of projects outside the study area. The future growth in traffic volumes has been calculated at two percent (2.0%) per year. Applied to existing Year 2023 traffic volumes results in a four percent (4.0%) growth in existing volumes to horizon year 2025.

6.2.2 Cumulative Projects Traffic Characteristics

In order to make a realistic estimate of future on-street conditions prior to implementation of the Project, the status of other known development projects (cumulative projects) has been researched at the City of Rialto and the City of Fontana. With this information, the potential impact of the proposed Project can be evaluated within the context of the cumulative impact of all ongoing development. Based on our research, there are six (6) cumulative projects located in the City of Rialto and five (5) cumulative projects located in the City of Fontana within the vicinity of the subject site. These eleven (11) planned and/or approved cumulative projects were considered in the cumulative traffic analysis for this project.

Table 6-1 provides the location and a brief description for each of the eleven (11) cumulative projects. *Figure 6-3* graphically illustrates the location of the cumulative projects. These cumulative projects are expected to generate vehicular traffic, which may affect the operating conditions of the key study intersections.

Table 6-2 presents the development totals and resultant trip generation for the eleven (11) cumulative projects. As shown in *Table 6-2*, the eleven (11) cumulative projects are forecast to generate a combined total of 13,988 daily trips, with 1,106 trips (621 inbound and 485 outbound) forecast during the AM peak hour and 1,048 trips (487 inbound and 561 outbound) forecast during the PM peak hour.

The AM and PM peak hour traffic volumes associated with the eleven (11) cumulative projects in the Year 2025 are presented in *Figures 6-4* and *6-5*, respectively. Cumulative project trips were developed using the rates/equations contained within the 11th Edition of *Trip Generation* and/or from available traffic studies and distributed to the study area using traffic engineering judgement and/or available traffic studies.

6.2.3 Existing With Ambient Growth Year 2025 With Project Traffic Volumes

Figures 6-6 and *6-7* illustrate the Year 2025 forecast AM and PM peak hour existing plus ambient growth traffic volumes, without the inclusion of the trips generated by the proposed Project, respectively.

Figures 6-8 and *6-9* illustrate the Year 2025 forecast AM and PM peak hour existing plus ambient growth traffic volumes, with the inclusion of the trips generated by the proposed Project, respectively.

6.2.4 Existing With Ambient Growth Year 2025 With Cumulative With Project Traffic Volumes

Figures 6-10 and *6-11* illustrate the Year 2025 cumulative forecast AM and PM peak hour traffic volumes, without the inclusion of the trips generated by the proposed Project, respectively.

Figures 6-12 and *6-13* illustrate the Year 2025 cumulative forecast AM and PM peak hour traffic volumes, with the inclusion of the trips generated by the proposed Project, respectively.

**TABLE 6-1
LOCATION AND DESCRIPTION OF CUMULATIVE PROJECTS⁶**

No.	Cumulative Project	Location/Address	Description
<i>City of Rialto</i>			
1.	Durst Drive Warehouse	Northeast corner of Cedar Avenue and Durst Drive	Replacing 9.40 acres of contractor's storage yard with 201,239 SF industrial warehouse
2.	Foothill and Larch Residential Development	Southeast corner of West Foothill Boulevard and North Larch Avenue	70 DU multifamily
3.	Olive Avenue Development Project	North side of Baseline Road at West Jackson Street	679,607 SF industrial storage warehouse
4.	Renaissance East	Northeast corner of Ayala Drive and Renaissance Parkway	80,000 SF retail
5.	Charley's Cheesesteaks and Wings	Northwest corner of West Foothill Boulevard and North Larch Avenue	1,800 SF drive-thru restaurant
6.	Proposed Storage Facility	Northwest corner of West Foothill Boulevard and North Larch Avenue	82,000 SF storage
<i>City of Fontana</i>			
7.	United Gas Station and Car Wash	Southwest corner of Foothill Boulevard at Alder Avenue	8 VFP fueling station, 4,800 SF retail, and 2,587 SF car wash
8.	201 Apartment Units on 7 Acres	South side of Foothill Boulevard east of 17797 Foothill Boulevard	201 DU multifamily low-rise
9.	The Foothill Oasis	Southeast corner of Foothill Boulevard at Laurel Avenue	90 DU multifamily mid-rise
10.	Rock of Salvation	17993 Foothill Boulevard	15,486 SF church
11.	McDonald's	Northeast corner of Arrow Boulevard and Locust Avenue	3,895 SF drive-thru restaurant

Notes:

- SF = Square-feet
- DU = Dwelling Unit
- VFP = Vehicle Fueling Positions

⁶ Source: City of Rialto and Fontana Planning Department staff.

**TABLE 6-2
CUMULATIVE PROJECTS TRAFFIC GENERATION FORECAST⁷**

Cumulative Project Description	Daily 2-Way	AM Peak Hour			PM Peak Hour		
		In	Out	Total	In	Out	Total
1. Durst Drive Warehouse	980	131	18	149	18	113	131
2. Foothill and Larch Residential Development	472	7	21	28	23	13	36
3. Olive Avenue Development Project	1,162	89	27	116	34	88	122
4. Renaissance East	5,742	245	219	464	210	185	395
5. Charley's Cheesesteaks and Wings	631	31	29	60	23	21	44
6. Proposed Storage Facility	119	4	3	7	6	6	12
7. United Gas Station and Car Wash	1,634	40	37	77	53	51	104
8. 201 Apartment Units on 7 Acres	1,355	19	61	80	65	38	103
9. The Foothill Oasis	409	8	25	33	21	14	35
10. Rock of Salvation	118	3	2	5	4	4	8
11. McDonald's	1,366	44	43	87	30	28	58
Cumulative Projects Total Trip Generation Potential	13,988	621	485	1,106	487	561	1,048

⁷ Source: *Trip Generation*, 11th Edition, Institute of Transportation Engineers (ITE), Washington, D.C. (2021), unless otherwise noted.

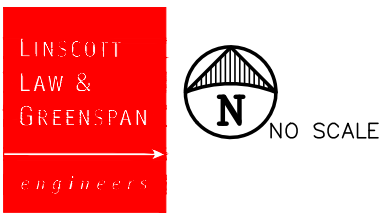
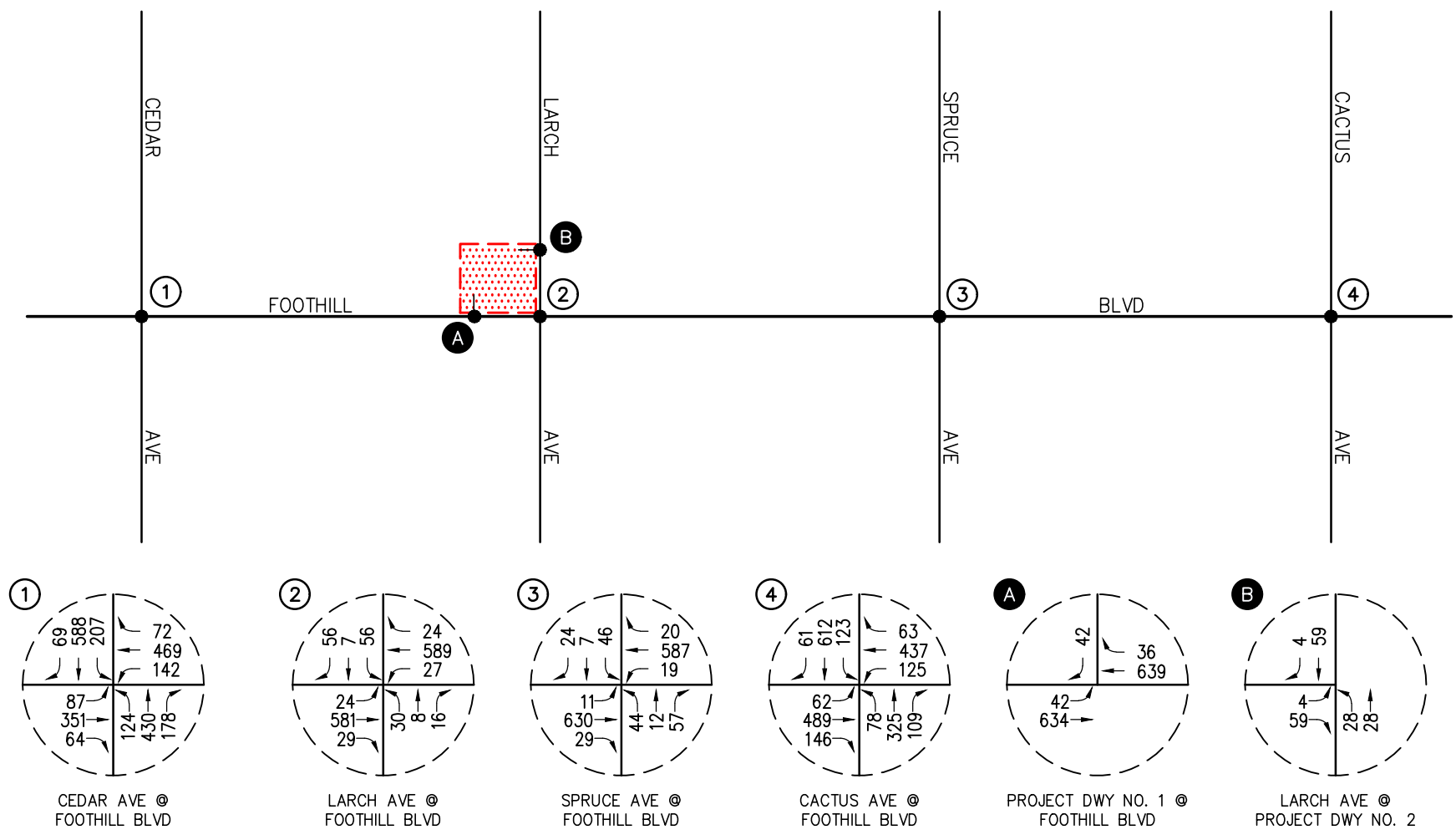

KEY

= STUDY INTERSECTION

[Red Dotted Box] = PROJECT SITE

FIGURE 6-1

EXISTING WITH PROJECT

AM PEAK HOUR TRAFFIC VOLUMES

FOOTHILL AND LARCH CHICK-FIL-A, RIALTO

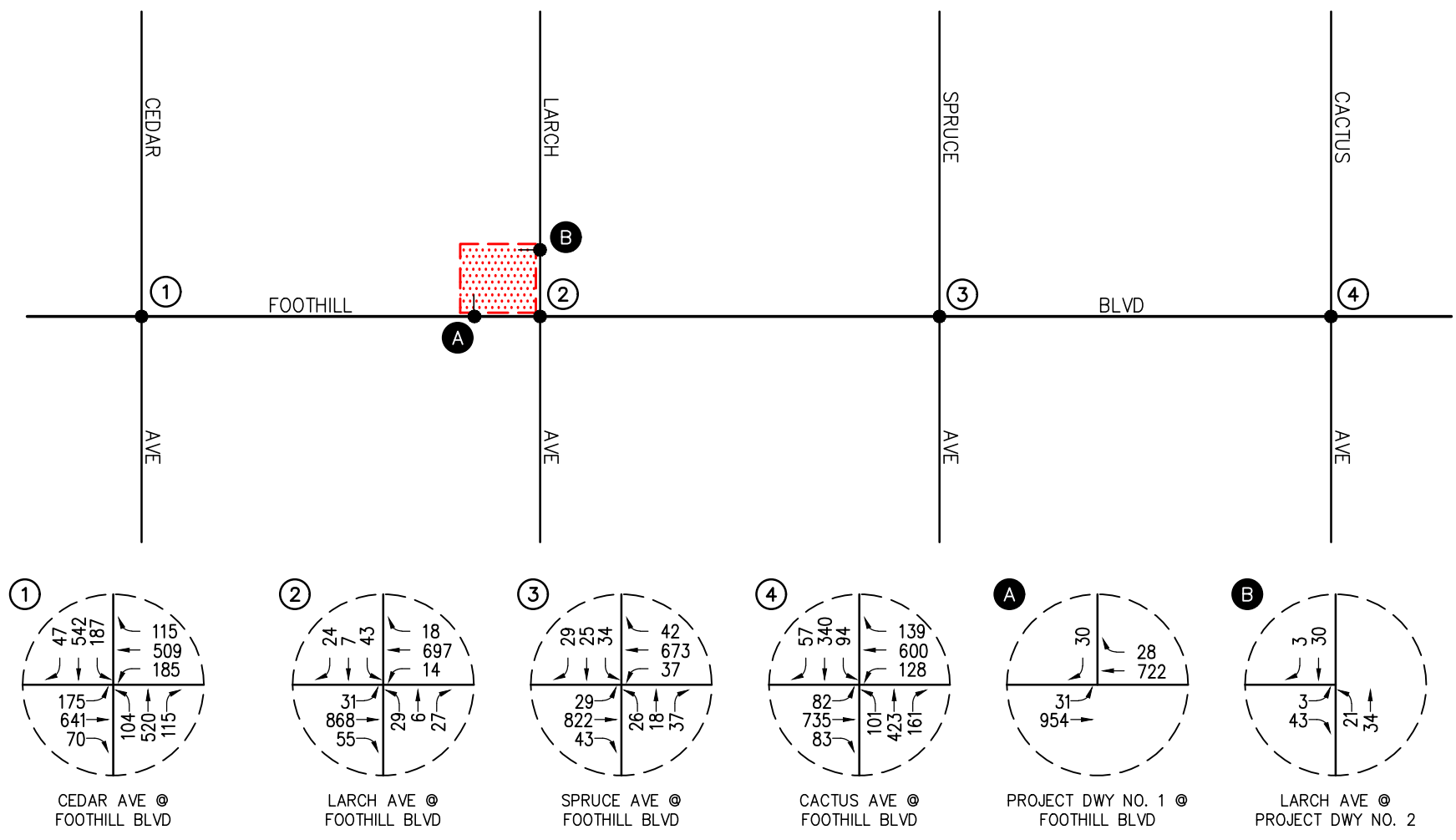

**LINSCOTT
LAW &
GREENSPAN**
engineers

NO SCALE

KEY

- # = STUDY INTERSECTION
- [Red Hatched Box] = PROJECT SITE

FIGURE 6-2
EXISTING WITH PROJECT
PM PEAK HOUR TRAFFIC VOLUMES
FOOTHILL AND LARCH CHICK-FIL-A, RIALTO

KEY

1. DURST DRIVE WAREHOUSE
2. FOOTHILL AND LARCH RESIDENTIAL DEVELOPMENT
3. OLIVE AVENUE DEVELOPMENT PROJECT
4. RENAISSANCE EAST
5. CHARLEY'S CHEESESTEAKS AND WINGS
6. PROPOSED STORAGE FACILITY
7. UNITED GAS STATION AND CAR WASH
8. 201 APARTMENT UNITS ON 7 ACRES
9. THE FOOTHILL OASIS
10. ROCK OF SALVATION
11. McDONALD'S

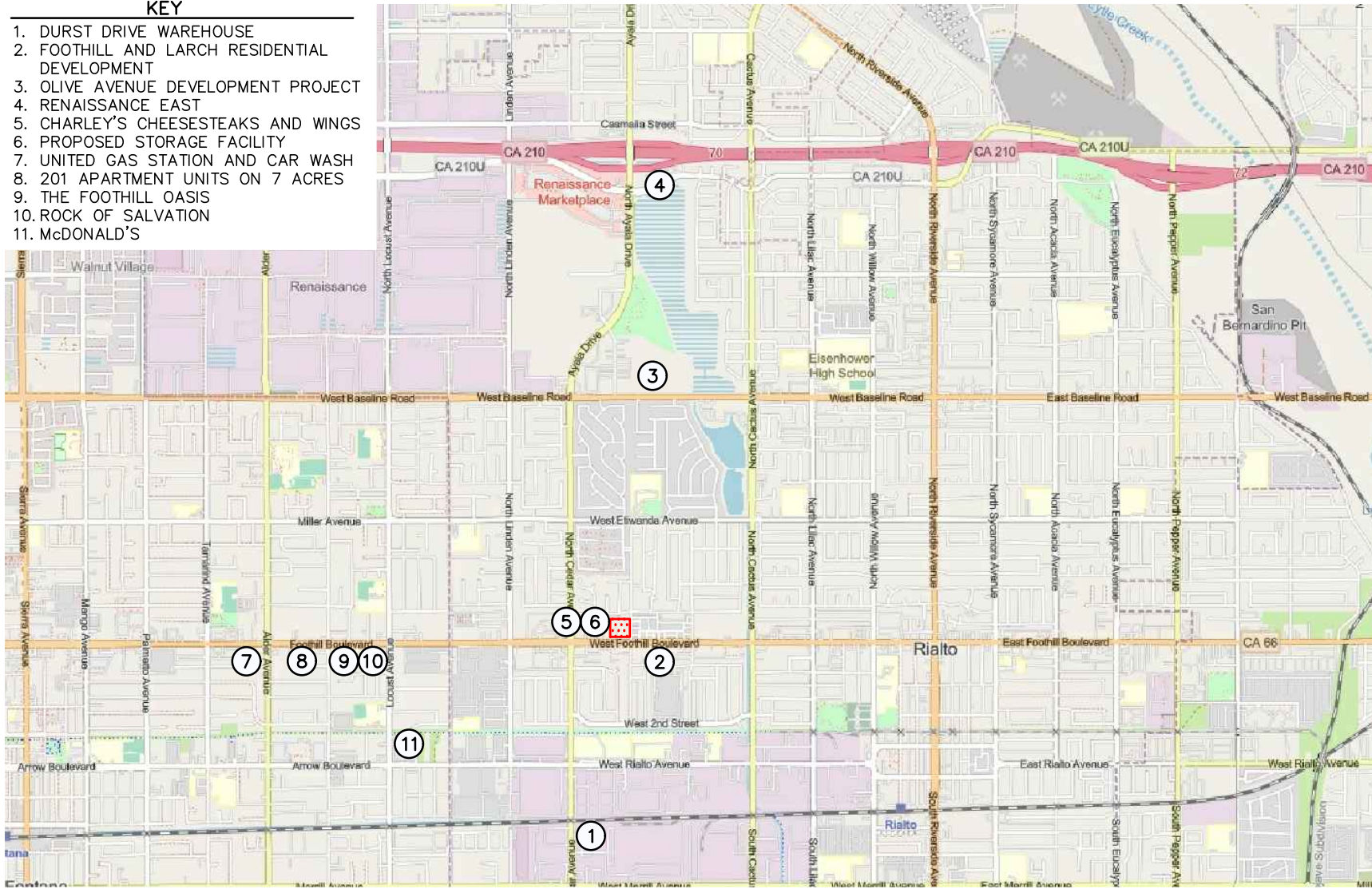

n:\4600\2234640 - foothill and larch chick-fil-a project, rialto\dwg\4640 f6-3.dwg LDP 09:03:00 08-03-2023 kopulsky

SOURCE: GOOGLE

KEY

- # = LOCATION OF CUMULATIVE PROJECT
- [Red Hatched Square] = PROJECT SITE

FIGURE 6-3

LOCATION OF CUMULATIVE PROJECTS
FOOTHILL AND LARCH CHICK-FIL-A, RIALTO

LINSCOTT
LAW &
GREENSPAN



NO SCALE

engineers

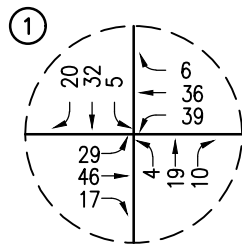
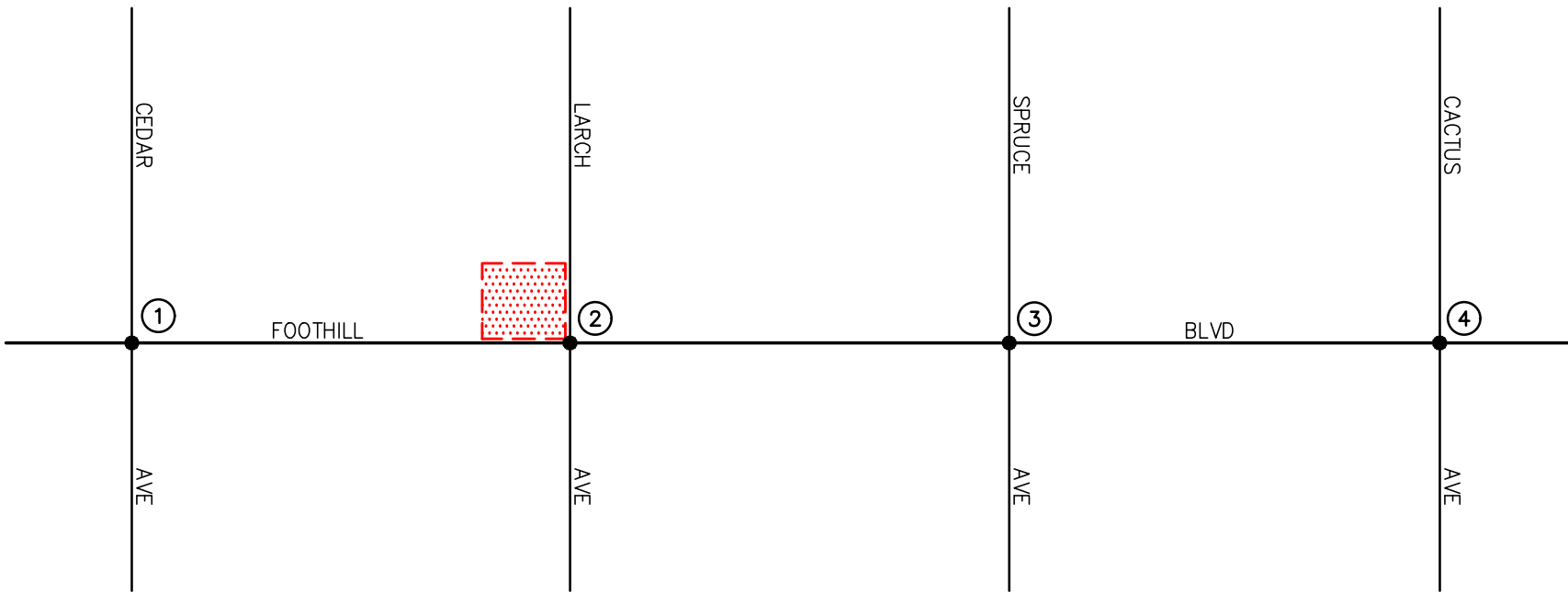

CEDAR AVE @
FOOTHILL BLVD

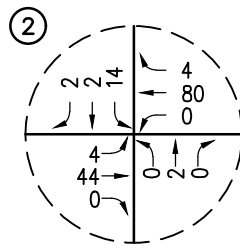

LARCH AVE @
FOOTHILL BLVD

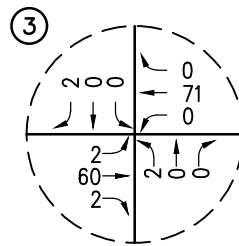

SPRUCE AVE @
FOOTHILL BLVD

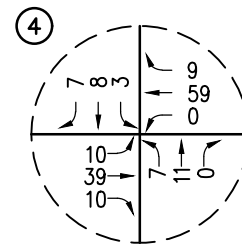

CACTUS AVE @
FOOTHILL BLVD

n:\4600\2234640 - foothill and larch chick-fil-a project, rialto\dwg\4640 f6-4.dwg LDP 15:16:00 06-27-2023 agular

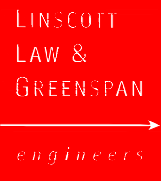

KEY

- # = STUDY INTERSECTION
- [Red Hatched Box] = PROJECT SITE

FIGURE 6-4

CUMULATIVE PROJECT ONLY
AM PEAK HOUR TRAFFIC VOLUMES
FOOTHILL AND LARCH CHICK-FIL-A, RIALTO

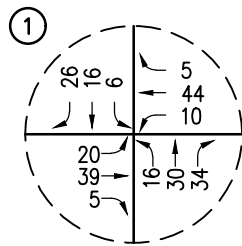
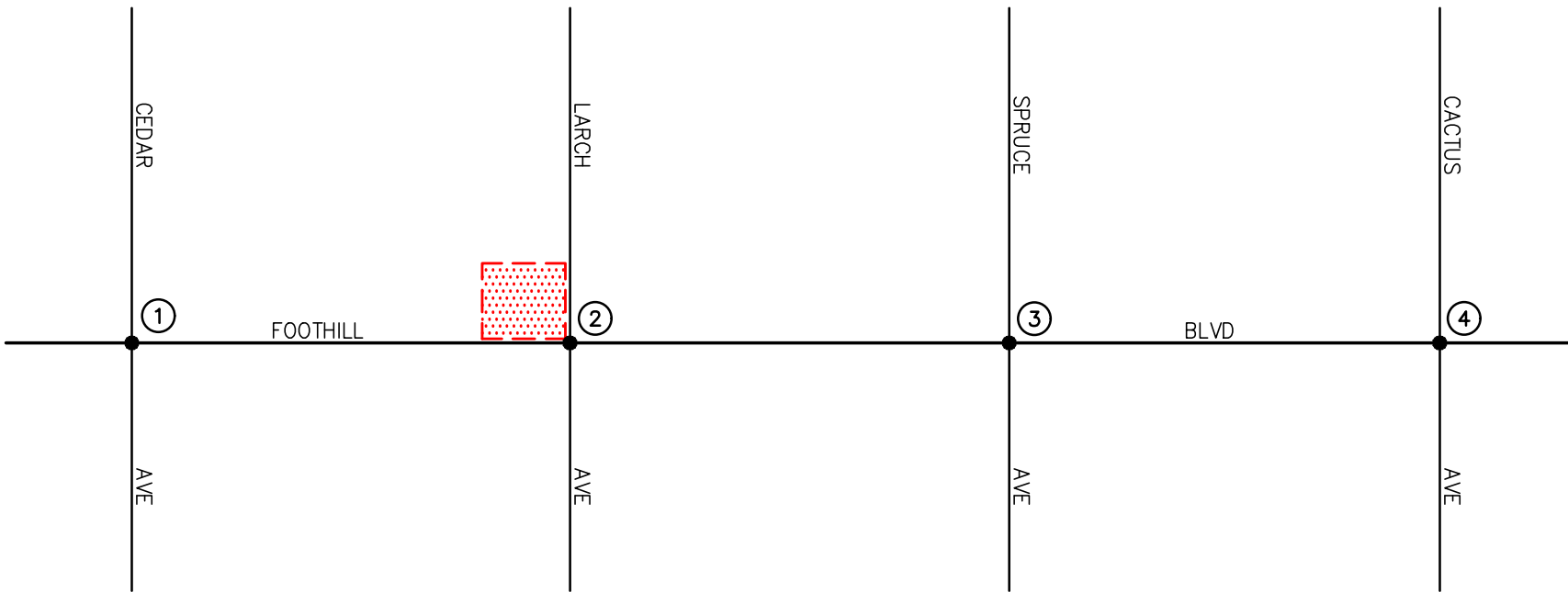

1 CEDAR AVE @
FOOTHILL BLVD

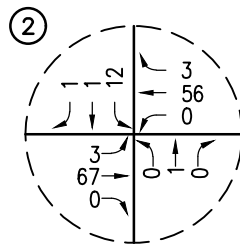

2 LARCH AVE @
FOOTHILL BLVD

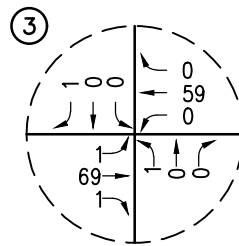

3 SPRUCE AVE @
FOOTHILL BLVD

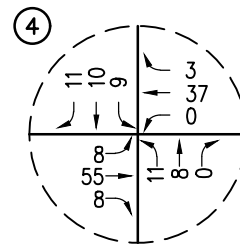

4 CACTUS AVE @
FOOTHILL BLVD

n:\4600\2234640 - foothill and larch chick-fil-a project, rialto\dwg\4640 f6-5.dwg LDP 15:17:04 06-27-2023 agular

KEY

= STUDY INTERSECTION

[Red hatched box] = PROJECT SITE

FIGURE 6-5

CUMULATIVE PROJECT ONLY
PM PEAK HOUR TRAFFIC VOLUMES
FOOTHILL AND LARCH CHICK-FIL-A, RIALTO

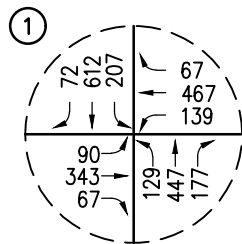
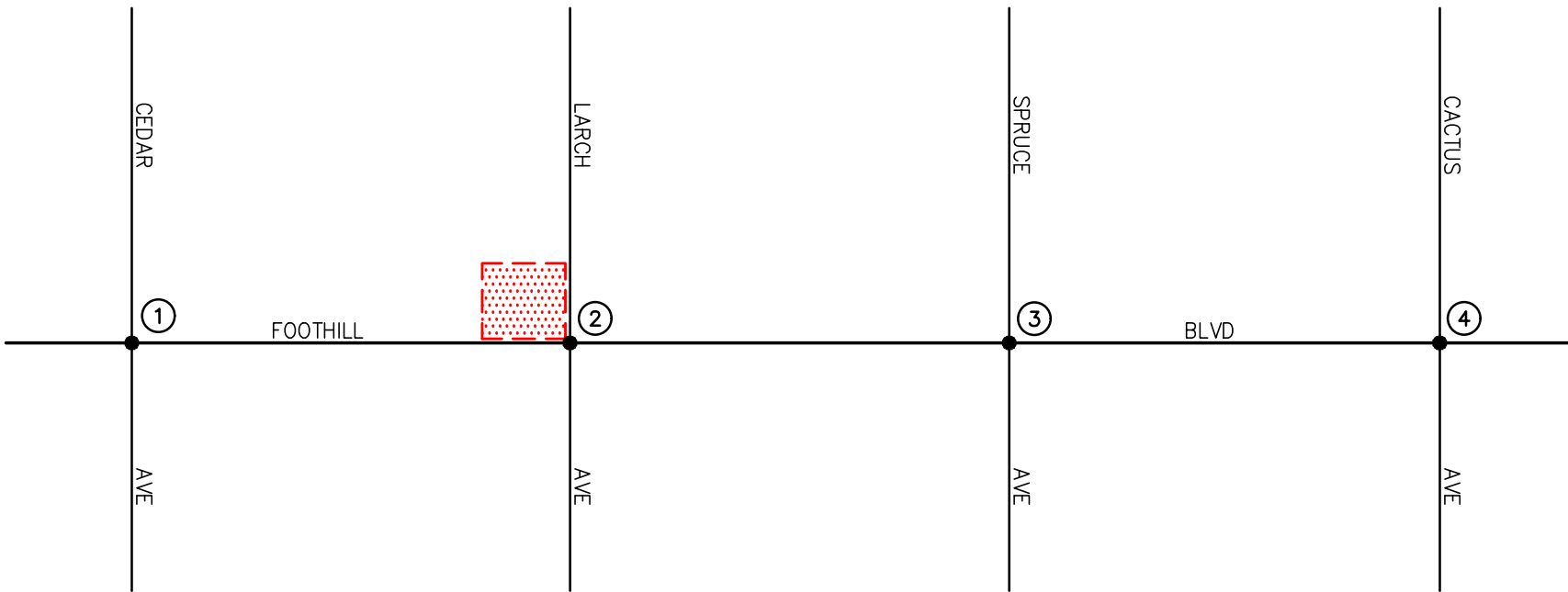

1 CEDAR AVE @
FOOTHILL BLVD

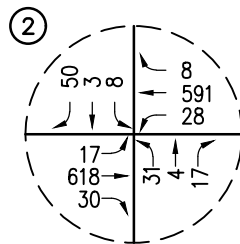

2 LARCH AVE @
FOOTHILL BLVD

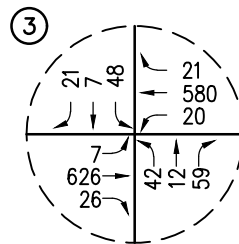

3 SPRUCE AVE @
FOOTHILL BLVD

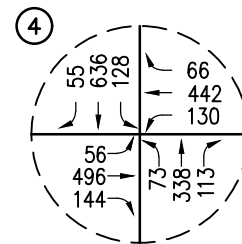

4 CACTUS AVE @
FOOTHILL BLVD

KEY

= STUDY INTERSECTION

[Red Hatched Box] = PROJECT SITE

FIGURE 6-6

YEAR 2025 EXISTING WITH AMBIENT GROWTH
WITHOUT PROJECT AM PEAK HOUR TRAFFIC VOLUMES

FOOTHILL AND LARCH CHICK-FIL-A, RIALTO

LINSCOTT
LAW &
GREENSPAN



NO SCALE

engineers

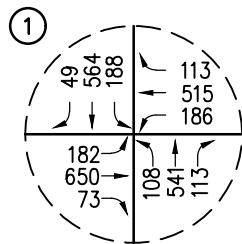
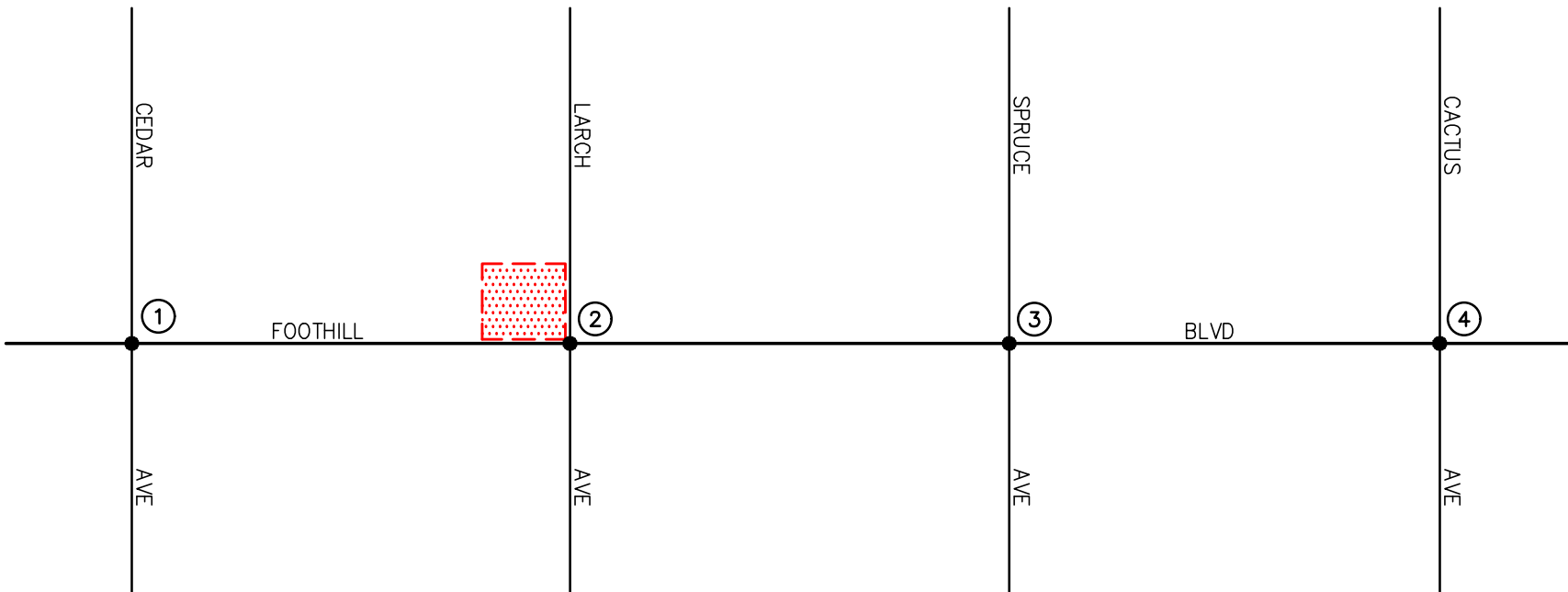

CEDAR AVE @
FOOTHILL BLVD

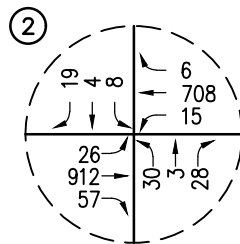

LARCH AVE @
FOOTHILL BLVD

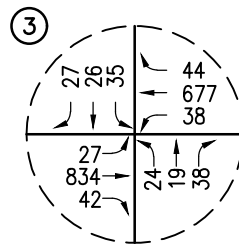

SPRUCE AVE @
FOOTHILL BLVD

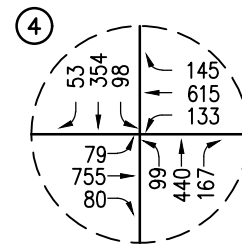

CACTUS AVE @
FOOTHILL BLVD

n:\4600\2234640 - foothill and larch chick-fil-a project, rialto\dwg\4640 f6-7.dwg LDP 15:18:54 06-27-2023 aguilera



KEY

= STUDY INTERSECTION

[Red hatched box] = PROJECT SITE

FIGURE 6-7

YEAR 2025 EXISTING WITH AMBIENT GROWTH
WITHOUT PROJECT PM PEAK HOUR TRAFFIC VOLUMES

FOOTHILL AND LARCH CHICK-FIL-A, RIALTO

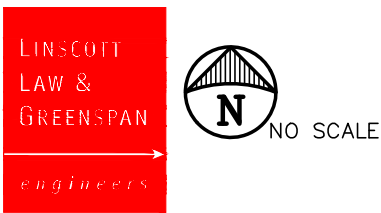
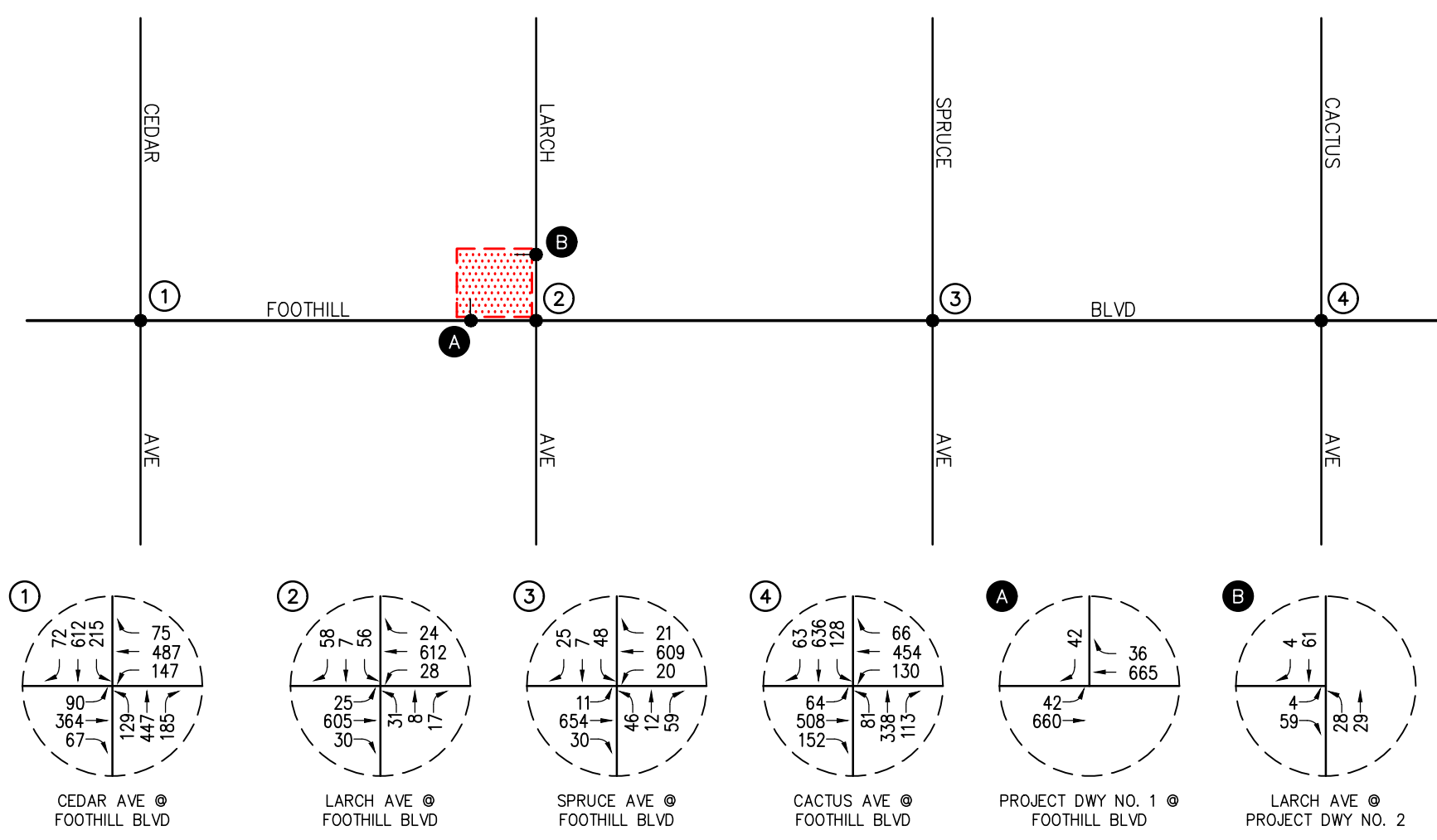

KEY

= STUDY INTERSECTION

[Red Dotted Box] = PROJECT SITE

FIGURE 6-8

**YEAR 2025 EXISTING WITH AMBIENT GROWTH
WITH PROJECT AM PEAK HOUR TRAFFIC VOLUMES**
FOOTHILL AND LARCH CHICK-FIL-A, RIALTO

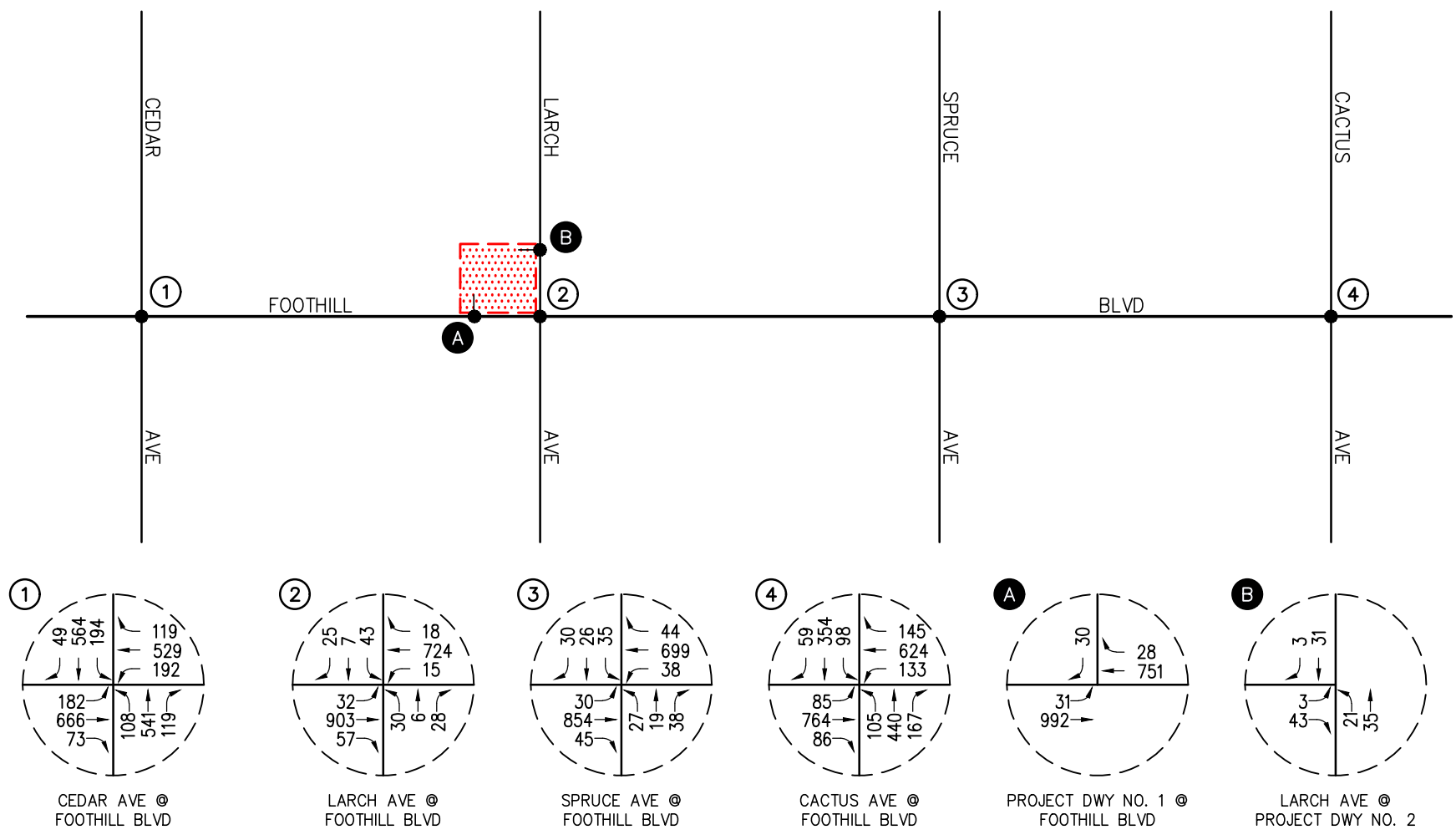

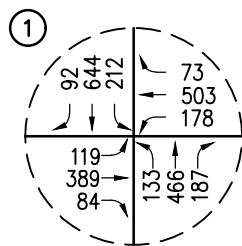
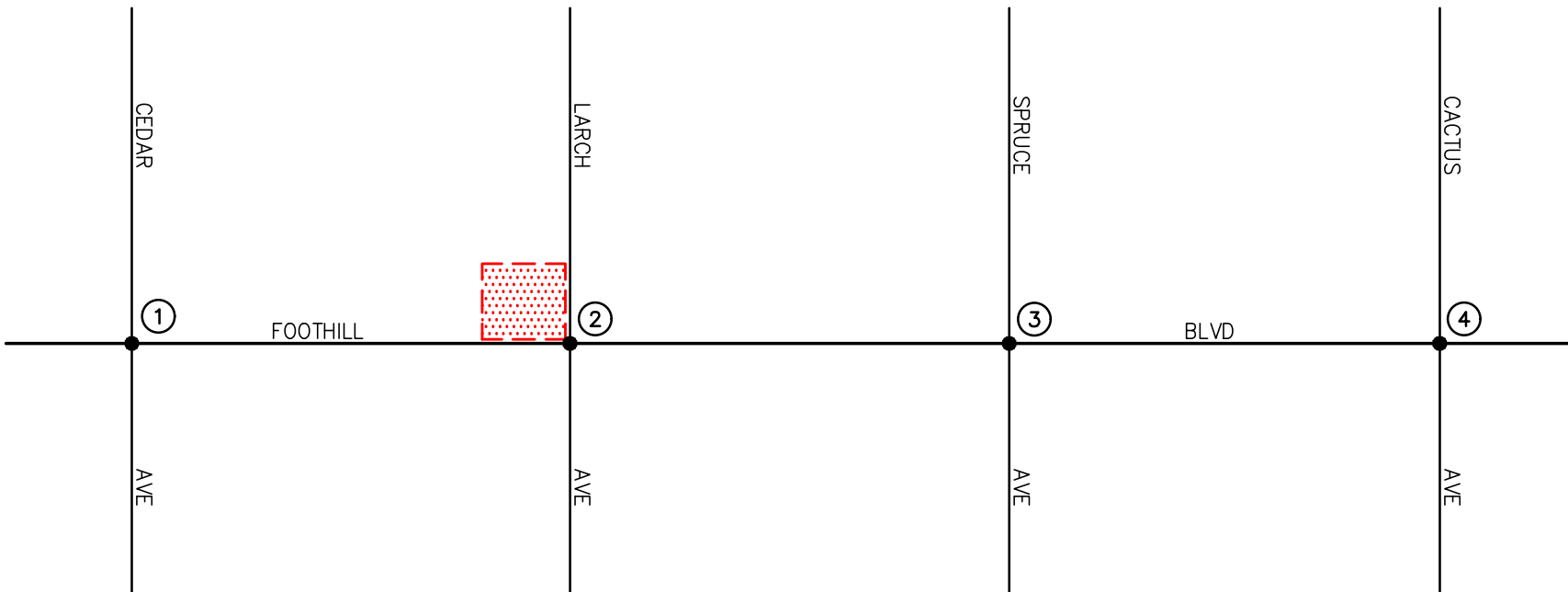

1 CEDAR AVE @
FOOTHILL BLVD

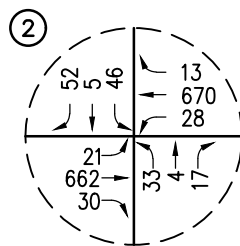

2 LARCH AVE @
FOOTHILL BLVD

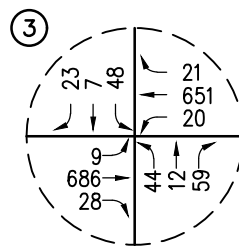

3 SPRUCE AVE @
FOOTHILL BLVD

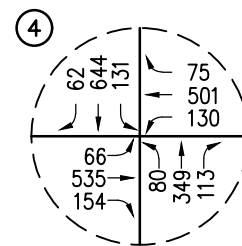

4 CACTUS AVE @
FOOTHILL BLVD

n:\4600\2234640 - foothill and larch chick-fil-a, rialto.dwg\4640 f6-10.dwg LDP 11:28:46 07-12-2023 aguilar



KEY

- ① = STUDY INTERSECTION
- ▨ = PROJECT SITE

FIGURE 6-10

YEAR 2025 EXISTING WITH AMBIENT GROWTH WITH CUMULATIVE
WITHOUT PROJECT AM PEAK HOUR TRAFFIC VOLUMES
FOOTHILL AND LARCH CHICK-FIL-A, RIALTO

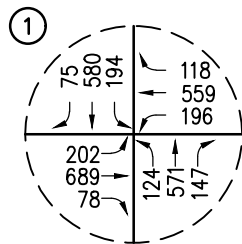
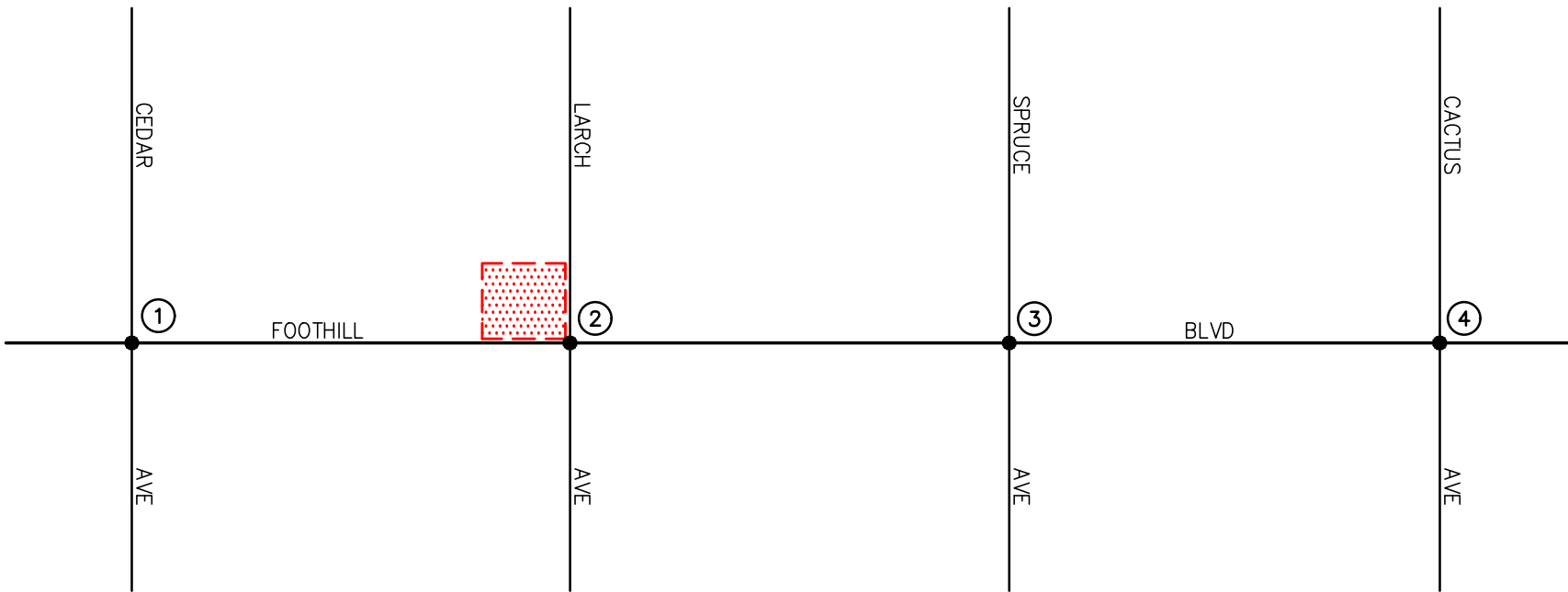

1 CEDAR AVE @
FOOTHILL BLVD

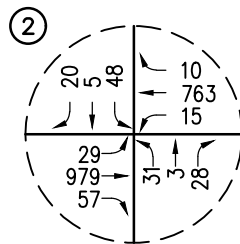

2 LARCH AVE @
FOOTHILL BLVD

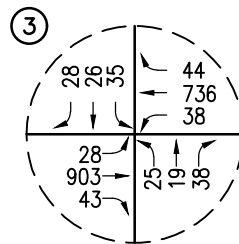

3 SPRUCE AVE @
FOOTHILL BLVD

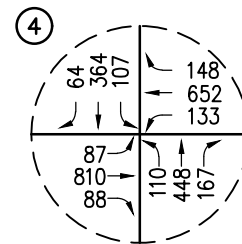

4 CACTUS AVE @
FOOTHILL BLVD

KEY

= STUDY INTERSECTION

[Red hatched box] = PROJECT SITE

FIGURE 6-11

YEAR 2025 EXISTING WITH AMBIENT GROWTH WITH CUMULATIVE
WITHOUT PROJECT PM PEAK HOUR TRAFFIC VOLUMES

FOOTHILL AND LARCH CHICK-FIL-A, RIALTO

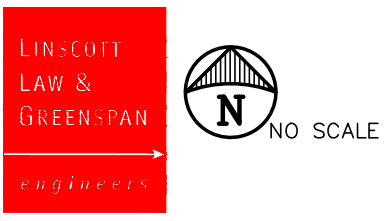
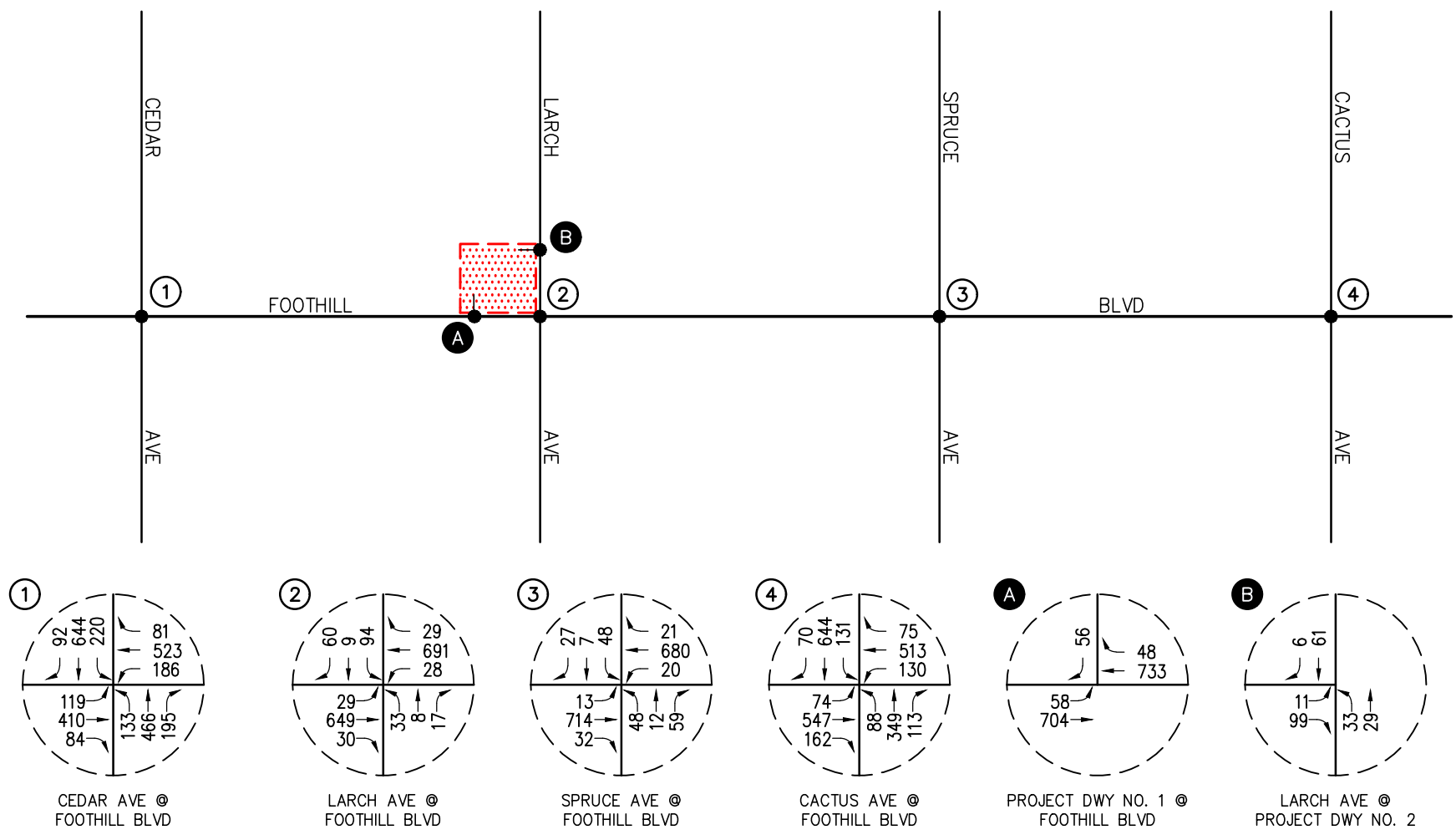

KEY

⊕ = STUDY INTERSECTION

▨ = PROJECT SITE

FIGURE 6-12

YEAR 2025 EXISTING WITH AMBIENT GROWTH WITH CUMULATIVE WITH PROJECT AM PEAK HOUR TRAFFIC VOLUMES
FOOTHILL AND LARCH CHICK-FIL-A, RIALTO

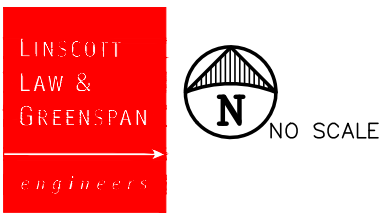
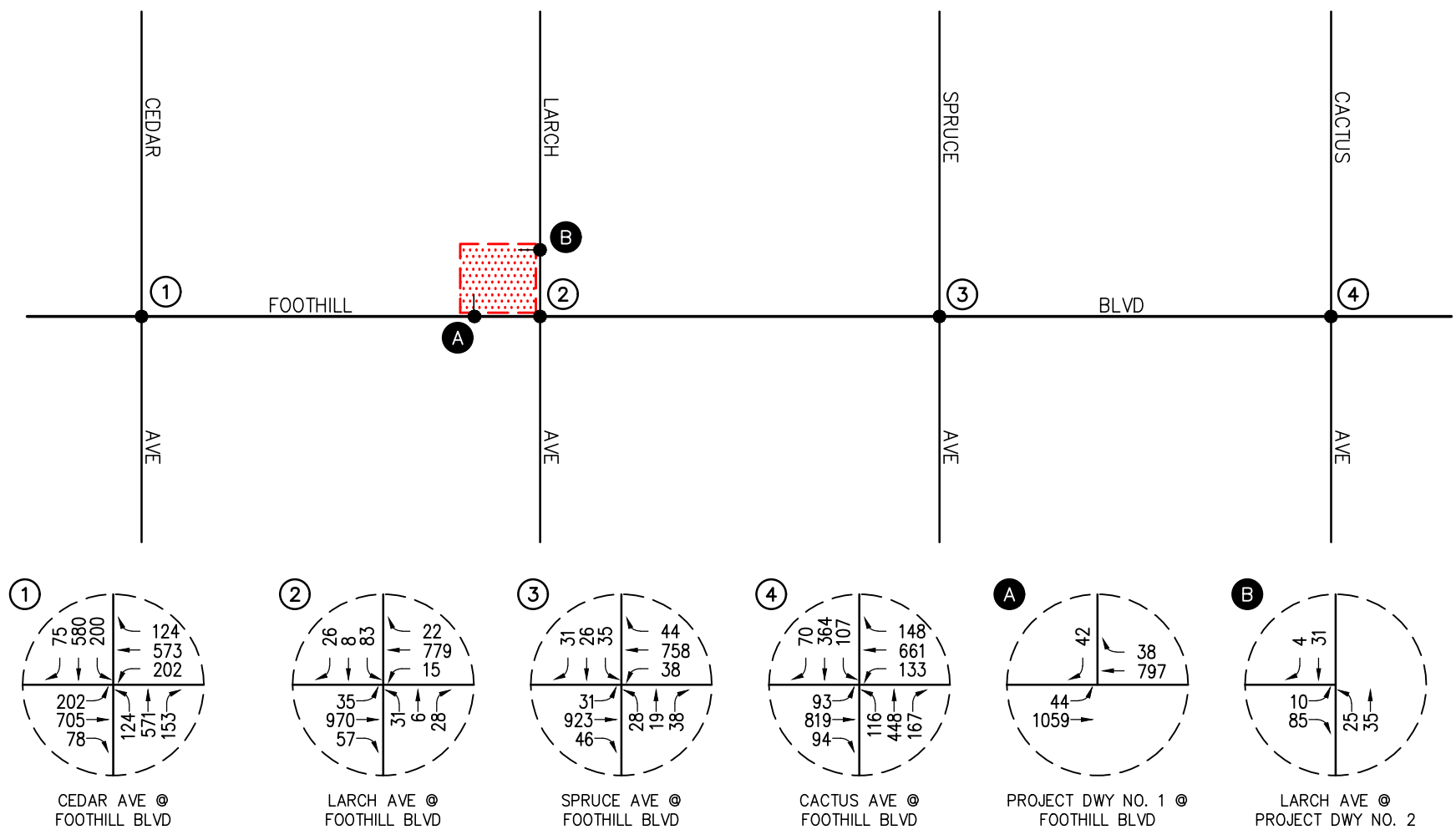

KEY

= STUDY INTERSECTION

[Red Hatched Box] = PROJECT SITE

FIGURE 6-13

YEAR 2025 EXISTING WITH AMBIENT GROWTH WITH CUMULATIVE WITH PROJECT PM PEAK HOUR TRAFFIC VOLUMES
FOOTHILL AND LARCH CHICK-FIL-A, RIALTO

7.0 EXISTING WITH PROJECT ANALYSIS

Table 7-1 summarizes the peak hour Level of Service results at the four (4) key study intersections for existing traffic conditions, without and with the proposed Project. The first column (1) of Delay/LOS values in *Table 7-1* presents a summary of Existing AM and PM peak hour traffic conditions. The second column (2) presents forecast Existing With Project traffic conditions. The third column (3) shows whether the traffic associated with the Project will have an impact based on the LOS standards and impact criteria defined in this report.

7.1 Existing Traffic Conditions

Review of column (1) of *Table 7-1* indicates that for Existing traffic conditions, the four (4) key study intersections currently operate at acceptable LOS D or better during the AM and PM peak hours when compared to the LOS standards defined in this report.

7.2 Existing With Project Traffic Conditions

Review of columns (2) and (3) of *Table 7-1* indicates that traffic associated with the proposed Project ***will not*** impact the four (4) key study intersections when compared to the LOS standards and impact criteria specified in this report. The four (4) key study intersections currently operate and are forecast to continue to operate at an acceptable LOS during the AM and PM peak hours with the addition of Project generated traffic to existing traffic.

Appendix C contains the Delay/LOS calculation worksheets for Existing and Existing With Project Traffic Conditions.

TABLE 7-1
EXISTING WITH PROJECT CONDITIONS PEAK HOUR INTERSECTION CAPACITY ANALYSIS SUMMARY

Key Intersection	Minimum Acceptable LOS	Time Period	(1) Existing Traffic Conditions		(2) Existing With Project Traffic Conditions		(3) Impact	
			Delay	LOS	Delay	LOS	Delay Increase	Yes/No
1. Cedar Avenue at Foothill Boulevard	D	AM	34.4 s/v	C	34.6 s/v	C	0.2 s/v	No
		PM	36.9 s/v	D	37.1 s/v	D	0.2 s/v	No
2. Larch Avenue at Foothill Boulevard	D	AM	19.8 s/v	C	23.8 s/v	C ⁸	4.0 s/v	No
		PM	24.7 s/v	C	26.3 s/v	D ⁸	1.6 s/v	No
3. Spruce Avenue at Foothill Boulevard	D	AM	32.5 s/v	C	33.7 s/v	C	1.2 s/v	No
		PM	33.3 s/v	C	34.7 s/v	C	1.4 s/v	No
4. Cactus Avenue at Foothill Boulevard	D	AM	26.2 s/v	C	26.5 s/v	C	0.3 s/v	No
		PM	28.2 s/v	C	28.4 s/v	C	0.2 s/v	No

Notes:

- s/v = seconds per vehicle (delay)
- **Bold Delay/LOS values** indicate adverse service levels based on the LOS standards mentioned in this report.

⁸ The level of service calculation for this location includes the following project-specific improvement.

- Restripe the westbound right-turn lane to a shared through/right-turn lane.

8.0 EXISTING WITH AMBIENT GROWTH (YEAR 2025) WITH PROJECT ANALYSIS

Table 8-1 summarizes the AM and PM peak hour Level of Service results at the four (4) key study intersections for Existing With Ambient Growth (Year 2025) With Project traffic conditions. The first column (1) of Delay/LOS values in *Table 8-1* presents a summary of existing AM and PM peak hour traffic conditions (which were also presented in *Table 7-1*). The second column (2) presents forecast existing with ambient growth (Year 2025) traffic conditions and the third column (3) identifies forecast existing with ambient growth (Year 2025) with project traffic conditions. The fourth column (4) indicates whether the traffic associated with the Project will have an impact based on the LOS standards and the impact criteria defined in this report.

8.1 Existing With Ambient Growth (Year 2025) Without Project Traffic Conditions

An analysis of future (Year 2025) traffic conditions indicates that the addition of ambient traffic growth *will not* impact the four (4) key study intersections. The four (4) key study intersections are forecast to continue to operate at acceptable levels of service during the AM and PM peak hours with the addition of ambient traffic growth.

8.2 Existing With Ambient Growth (Year 2025) With Project Traffic Conditions

Review of columns (3) and (4) of *Table 8-1* indicates that traffic associated with the proposed Project *will not* impact the four (4) key study intersections when compared to the LOS standards and impact criteria specified in this report. The four (4) key study intersections are forecast to continue to operate at an acceptable LOS during the AM and PM peak hours with the addition of Project generated traffic to ambient traffic growth (Year 2025).

Appendix D contains the Delay/LOS calculation worksheets for Existing With Ambient Growth Year 2025 Without and With Project Traffic Conditions.

TABLE 8-1

EXISTING WITH AMBIENT GROWTH YEAR 2025 WITH PROJECT CONDITIONS PEAK HOUR INTERSECTION CAPACITY ANALYSIS SUMMARY

Key Intersection	Minimum Acceptable LOS	Time Period	(1) Existing Traffic Conditions		(2) Existing With Ambient Growth Without Project Traffic Conditions		(3) Existing With Ambient Growth With Project Traffic Conditions		(4) Impact	
			Delay	LOS	Delay	LOS	Delay	LOS	Delay Increase	Yes/No
			1. Cedar Avenue at Foothill Boulevard	D	AM	34.4 s/v	C	35.9 s/v	D	36.2 s/v
		PM	36.9 s/v	D	37.2 s/v	D	37.4 s/v	D	0.2 s/v	No
2. Larch Avenue at Foothill Boulevard	D	AM	19.8 s/v	C	20.7 s/v	C	25.2 s/v	D ⁹	4.5 s/v	No
		PM	24.7 s/v	C	26.4 s/v	D	28.3 s/v	D ⁹	1.9 s/v	No
3. Spruce Avenue at Foothill Boulevard	D	AM	32.5 s/v	C	34.0 s/v	C	35.2 s/v	D	1.2 s/v	No
		PM	33.3 s/v	C	34.8 s/v	C	36.2 s/v	D	1.4 s/v	No
4. Cactus Avenue at Foothill Boulevard	D	AM	26.2 s/v	C	26.4 s/v	C	26.7 s/v	C	0.3 s/v	No
		PM	28.2 s/v	C	28.3 s/v	C	28.5 s/v	C	0.2 s/v	No

Notes:

- s/v = seconds per vehicle (delay)
- **Bold Delay/LOS values** indicate adverse service levels based on the LOS standards mentioned in this report.

⁹ The level of service calculation for this location includes the following project-specific improvement.

- Restripe the westbound right-turn lane to a shared through/right-turn lane.

9.0 EXISTING WITH A.G. (YEAR 2025) WITH CUMULATIVE WITH PROJECT ANALYSIS

Table 9-1 summarizes the AM and PM peak hour Level of Service results at the four (4) key study intersections for Existing With Ambient Growth (Year 2025) With Cumulative With Project traffic conditions. The first column (1) of Delay/LOS values in *Table 9-1* presents forecast existing with ambient growth (Year 2025) with cumulative traffic conditions. The second column (2) identifies forecast existing with ambient growth (Year 2025) with cumulative with project traffic conditions. The third column (3) indicates whether the traffic associated with the Project will have an impact based on the LOS standards and the impact criteria defined in this report. The fourth column (4) presents the resultant level of service with the inclusion of recommended traffic improvements, where needed, to achieve an acceptable level of service.

9.1 Existing With A.G. (Year 2025) With Cumulative Without Project Traffic Conditions

An analysis of future (Year 2025) traffic conditions indicates that the addition of ambient traffic growth and cumulative traffic *will not* impact the four (4) key study intersections. The four (4) key study intersections are forecast to continue to operate at acceptable levels of service during the AM and PM peak hours with the addition of ambient traffic growth and cumulative traffic.

9.2 Existing With A.G. (Year 2025) With Cumulative With Project Traffic Conditions

Review of columns (2) and (3) of *Table 9-1* indicates that traffic associated with the proposed Project will cumulatively impact one (1) of the four (4) key study intersections when compared to the LOS standards and impact criteria specified in this report. The remaining three (3) key study intersections are forecast to continue to operate at an acceptable LOS during the AM and PM peak hours with the addition of Project generated traffic to ambient traffic growth (Year 2025) and cumulative traffic. The location forecast to operate at an adverse LOS is as follows:

<u>Key Intersection</u>	<u>AM Peak Hour</u>		<u>PM Peak Hour</u>	
	<u>Delay (s/v)</u>	<u>LOS</u>	<u>Delay (s/v)</u>	<u>LOS</u>
2. Larch Avenue at Foothill Boulevard	50.7 s/v	F	41.3 s/v	E

Although the intersection of Larch Avenue at Foothill Boulevard is forecasted to operate at a deficient level of service, it is our understanding that a traffic signal is planned at this location. The implementation of a traffic signal at this intersection will improve this deficiency and as shown in column 4 of *Table 9-1*, the intersection is forecast to operate at an acceptable level of service during the AM peak hour and PM peak hour. A traffic signal warrant analysis and fair share analysis for this intersection is conducted in the following sections of this report.

Appendix E contains the Delay/LOS calculation worksheets for Existing With Ambient Growth Year 2025 With Cumulative Without and With Project Traffic Conditions.

TABLE 9-1

EXISTING WITH AMBIENT GROWTH YEAR 2025 WITH CUMULATIVE WITH PROJECT CONDITIONS PEAK HOUR INTERSECTION CAPACITY ANALYSIS SUMMARY

Key Intersection	Minimum Acceptable LOS	Time Period	(1) Existing With Ambient Growth Without Project Traffic Conditions		(2) Existing With Ambient Growth With Project Traffic Conditions		(3) Impact		(4) With Improvements	
			Delay	LOS	Delay	LOS	Delay Increase	Yes/No	Delay	LOS
1. Cedar Avenue at Foothill Boulevard	D	AM	37.1 s/v	D	38.9 s/v	D	1.8 s/v	No	--	--
		PM	37.9 s/v	D	38.1 s/v	D	0.2 s/v	No	--	--
2. Larch Avenue at Foothill Boulevard	D	AM	24.2 s/v	C	50.7 s/v	F¹⁰	26.5 s/v	Yes	11.2 s/v	B
		PM	30.4 s/v	D	41.3 s/v	E¹⁰	10.9 s/v	Yes	8.9 s/v	A
3. Spruce Avenue at Foothill Boulevard	D	AM	31.2 s/v	C	32.3 s/v	C	1.1 s/v	No	--	--
		PM	32.1 s/v	C	33.5 s/v	C	1.4 s/v	No	--	--
4. Cactus Avenue at Foothill Boulevard	D	AM	27.1 s/v	C	27.4 s/v	C	0.3 s/v	No	--	--
		PM	28.6 s/v	C	28.7 s/v	C	0.1 s/v	No	--	--

Notes:

- s/v = seconds per vehicle (delay)
- **Bold Delay/LOS values** indicate adverse service levels based on the LOS standards mentioned in this report.

¹⁰ The level of service calculation for this location includes the following project-specific improvement.

- Restripe the westbound right-turn lane to a shared through/right-turn lane.

10.0 TRAFFIC SIGNAL WARRANT ANALYSIS

The level of service analysis at the key unsignalized impacted study intersection that is recommended to be signalized are supplemented with an assessment of the need for signalization of those intersections. This assessment is made on the basis of signal warrant criteria adopted by Caltrans. For this study, the need for signalization is assessed on the basis of the peak-hour traffic signal warrant; Warrant #3 described in the *California Manual on Uniform Traffic Control Devices (MUTCD)*. Warrant #3 has two parts: 1) Part A evaluates peak hour vehicle delay for traffic on the minor street approach with the highest delay and 2) Part B evaluates peak-hour traffic volumes on the major and minor streets. This method provides an indication of whether peak-hour traffic conditions or peak-hour traffic volume levels are, or would be, sufficient to justify installation of a traffic signal. Other traffic signal warrants are available; however, they cannot be checked under future conditions because they rely on data for which forecasts are not available (such as accidents, pedestrian volume, and four- or eight-hour vehicle volumes).

The decision to install a traffic signal should not be based purely on the warrants alone. Instead, the installation of a signal should be considered and further analysis performed when one or more of the warrants are satisfied. Additionally, engineering judgment is exercised on a case-by-case basis to evaluate the effect a traffic signal will have on certain types of accidents and traffic conditions at the subject intersection as well as at adjacent intersections.

10.1 Existing With A.G. (Year 2025) With Cumulative Without Project Traffic Conditions

The results of the peak-hour traffic signal warrant analysis for Existing With Ambient Growth (Year 2025) With Cumulative Without Project traffic conditions are summarized in column (1) of *Table 10-1*. The results indicate that the intersection of Larch Avenue at Foothill Boulevard has future traffic conditions that would exceed the volume thresholds of Warrant #3, Part B for the AM peak hour. Thus, a traffic signal is recommended at this location.

10.2 Existing With A.G. (Year 2025) With Cumulative With Project Traffic Conditions

The results of the peak-hour traffic signal warrant analysis for the Existing With Ambient Growth (Year 2025) With Cumulative With Project traffic conditions are summarized in column (2) of *Table 10-1*. The results indicate that the intersection of Larch Avenue at Foothill Boulevard has future traffic conditions that would exceed the volume thresholds of Warrant #3, Part B for the AM and PM peak hours. Thus, a traffic signal is recommended at this location.

The Traffic Signal Warrant Analysis worksheets for the intersection of Larch Avenue at Foothill Boulevard are contained in *Appendix F*.

TABLE 10-1
TRAFFIC SIGNAL WARRANT ANALYSIS SUMMARY

Key Intersection	Time Period	(1) Existing With Ambient Growth With Cumulative Without Project Traffic Conditions		(2) Existing With Ambient Growth With Cumulative With Project Traffic Conditions	
		Part A of Warrant 3 Satisfied?	Part B of Warrant 3 Satisfied?	Part A of Warrant 3 Satisfied?	Part B of Warrant 3 Satisfied?
2. Larch Avenue at Foothill Boulevard	AM	No	Yes	No	Yes
	PM	No	No	No	Yes

Notes:

- Signal Warrant checks based on Warrant 3, Part A - Peak-Hour Delay Warrant and Part B - Peak-Hour Volume Warrant contained in the *California MUTCD*.

11.0 SITE ACCESS AND INTERNAL CIRCULATION EVALUATION

11.1 Site Access Evaluation

Table 11-1 summarizes the intersection operations at the two (2) proposed Project driveways for future traffic conditions with the proposed Project. As shown in column (1), the proposed Project driveways are forecast to operate at acceptable LOS B or better during the AM and PM peak hours under Existing With Project traffic conditions.

As shown in column (2), the proposed project driveways are forecast to operate at acceptable LOS B or better during the AM and PM peak hours under Existing With Ambient Growth With Project traffic conditions.

As shown in column (3), the proposed project driveways are forecast to operate at acceptable LOS B or better during the AM and PM peak hours under Existing With Ambient Growth With Cumulative With Project traffic conditions.

11.1.1 Queuing Evaluation

To address stacking/storage lengths at the proposed Project driveways, a queuing evaluation was prepared for Project Driveway No. 1 (i.e. for the southbound right-turn lane and the eastbound left-turn lane) and for Project Driveway No. 2 (i.e. eastbound left-turn/right-turn lane). The queuing evaluation was conducted based on projected Existing With Ambient Growth (Year 2025) With Cumulative With Project traffic volumes.

Table 11-2 presents the 95th percentile queuing analysis results for the aforementioned locations for Existing With Ambient Growth (Year 2025) With Cumulative With Project traffic conditions. Review of *Table 11-2* indicates that adequate storage is provided for Project Driveway No. 1 (i.e. southbound right-turn lane and eastbound left-turn lane) and for Project Driveway No. 2 (i.e. eastbound left-turn/right-turn lane) during the AM and PM peak hours for Existing With Ambient Growth (Year 2025) With Cumulative With Project traffic conditions.

Appendix G contains the detailed HCM/LOS calculation worksheets for the project driveways.

11.2 Internal Circulation Evaluation

The on-site circulation layout of the proposed Project as illustrated in *Figure 2-2* on an overall basis is adequate. Curb return radii are generally adequate for small service/delivery (FedEx, UPS) trucks, trash trucks and fire trucks.

11.3 Chick-fil-A Drive-Through

To confirm the adequacy of storage provided for the proposed Chick-fil-A drive-through lane, existing queuing observations were conducted at the following three (3) existing Chick-fil-A restaurants.

- Chick-fil-A Irvine, located at 4127 Campus Drive
- Chick-fil-A San Juan Capistrano, located at 31872 Del Obispo Street

- Chick-fil-A Yucaipa, located at 31479 Avenue E

Drive-through queuing observations were conducted at the three (3) locations on two weekdays (Thursday and Friday) and on a Saturday during the morning, mid-day and evening service periods, generally between the hours of 7:00 AM and 9:00 AM, 11:00 AM and 2:00 PM, and 4:00 PM and 7:00 PM. The queuing observations for the Irvine Chick-fil-A and San Juan Capistrano Chick-fil-A were conducted by Transportation Studies Inc. (TSI) on Thursday December 9, 2021, Friday December 10, 2021 and Saturday December 11, 2021. The queuing observations for the Yucaipa Chick-fil-A were conducted by TSI on Thursday December 16, 2021, Friday December 17, 2021 and Saturday December 18, 2021. The vehicular queues observed at the three (3) sites were recorded at 5-minute intervals.

Tables 11-3, 11-4 and 11-5 summarize the Queue Frequency that was observed at the three sites for the weekday (Thursday), weekday (Friday) and weekend (Saturday) peak periods, respectively. Our evaluation of this data indicates that on average during the weekday (Thursday) peak periods, an average queue of 12 vehicles in the drive-through lane can be expected, with an 85th percentile queue of approximately 19 vehicles, a 95th percentile queue of approximately 23 vehicles and a max queue of approximately 27 vehicles. Similarly, our evaluation of this data indicates that on average during the weekday (Friday) peak periods, an average queue of 12 vehicles in the drive-through lane can be expected, with an 85th percentile queue of approximately 18 vehicles, a 95th percentile queue of approximately 22 vehicles and a max queue of approximately 31 vehicles. In addition, our evaluation of this data also indicates that on average during the weekend (Saturday) peak periods, an average queue of 9 vehicles in the drive-through lane can be expected, with an 85th percentile queue of approximately 15 vehicles, a 95th percentile queue of approximately 18 vehicles and a max queue of approximately 27 vehicles. It should be noted that the 85th percentile queue is generally utilized when designing/sizing the length of the proposed drive-through lane.

In conclusion, the three (3) study sites experienced an 85th percentile queue range between 15 vehicles and 19 vehicles. As stated previously, the proposed Project will provide storage for up to 40 vehicles within the proposed drive-through lane without encroaching into the drive aisle. Therefore, the 85th percentile expected queues can be accommodated without interfering with internal circulation or causing congestion to the drive aisles. It should be noted that the proposed 40 vehicle storage drive-through lane can also accommodate the observed 95th percentile queues (i.e. queue range between 18 vehicles and 23 vehicles). Lastly, it should be noted that the proposed 40 vehicle storage drive-through lane can also accommodate the observed maximum queue of 31 vehicles, which only occurred one time and only at one site throughout the survey days.

Even though it is anticipated that the proposed drive-through lane will accommodate all potential queues on site, Chick-fil-A staff will implement the following program, on an as-needed basis during their peak operating times, to further ensure that vehicles will not queue back onto the public streets. The program consists of the following as provided by Chick-fil-A management staff:

- “Our restaurants are staffed so that if the drive-thru queuing begins stacking onto the street, team members go out and assist with ordering via Chick-fil-A’s iPad ordering system. Our operators use the iPad ordering during our peak hours of 11:30 am to 1:30 pm and any additional time when needed. The iPad ordering system allows team members to take orders, receive payment, and assist with traffic movement within the parking lot.
- Based on data from our other comparable stores, the iPad ordering system increases the Chick-fil-A drive thru speed of service by 30% than the typical speaker box. Putting people forward in the drive-through is one of our biggest competitive advantages in the market because it personally connects our team members with our valued guest. We want to continue this momentum by building a platform to supporting current and future innovations that increase capacity and put our people forward to care for our guest in every interaction. Our customers enjoy the face to face ordering over the standard drive-thru experience.”
- Along with face-to-face ordering, Chick-fil-A implemented a dual drive-through concept from the entrance of the drive-through to the pick-up window. The outer drive-through lane can be used for full order take and meal delivery, mobile pick up lane, or for a pickup point for smaller orders. The Operator has the flexibility to use the second lane as they see fit (during peak demand). Chick-fil-A team members will take orders and deliver orders in both lanes, hence the importance of the canopies to provide shade for the team members. Appropriate safety signage and protocols are placed throughout the drive-thru.
- It should be noted that Chick-fil-A team members will control the drive-through area after the pick-up window ensuring that only one vehicle will leave at a time after they receive their order.

Appendix H presents the drive-through queuing study data for the three (3) existing sites.

TABLE 11-1
PROJECT DRIVEWAY PEAK HOUR LEVELS OF SERVICE SUMMARY

Key Driveway	Control Type	Time Period	(1)		(2)		(3)	
			Existing With Project Traffic Conditions		Existing With A.G. (Year 2025) With Project Traffic Conditions		Existing With A.G. (Year 2025) With Cumulative With Project Traffic Conditions	
			Delay	LOS	Delay	LOS	Delay	LOS
A. Project Driveway 1 at Foothill Boulevard	One-Way	AM	12.2 s/v	B	12.3 s/v	B	13.1 s/v	B
	Stop	PM	12.4 s/v	B	12.6 s/v	B	13.2 s/v	B
B. Larch Avenue at Project Driveway 2	One-Way	AM	8.9 s/v	A	8.9 s/v	A	9.2 s/v	A
	Stop	PM	8.7 s/v	A	8.7 s/v	A	8.9 s/v	A

Notes:

- LOS = Level of Service, please refer to *Tables 3-1* and *3-2* for the LOS definitions
- s/v = seconds per vehicle

**TABLE 11-2
PROJECT DRIVEWAY QUEUING ANALYSIS¹¹**

Key Intersection	Proposed Storage Provided (feet)	Existing With Ambient Growth Year 2025 With Cumulative With Project Traffic Conditions			
		AM Peak Hour		PM Peak Hour	
		Max. Queue (feet)	Adequate Storage (Yes / No)	Max. Queue (feet)	Adequate Storage (Yes / No)
A. Project Driveway No. 1 at Foothill Boulevard					
<i>Southbound Right Turn</i>	115'	25'	Yes	25'	Yes
<i>Eastbound Left Turn</i>	145'	25'	Yes	25'	Yes
B. Larch Avenue at Project Driveway No. 2					
<i>Eastbound Left Turn/Right Turn</i>	70'	25'	Yes	25'	Yes

¹¹ Queue is based on the 95th Percentile Queue and is reported in total queue length (feet) per lane.

**TABLE 11-3
WEEKDAY (THURSDAY) QUEUING ANALYSIS SUMMARY**

Queue Length (Vehicles)	Queue Frequency of Vehicles Observed				Cumulative	
	Site #1 4127 Campus Dr, Irvine, CA	Site #2 31872 Del Obispo St, San Juan Cap, CA	Site #3 31479 Avenue E, Yucaipa, CA	Total	Frequency	Percentage
0	5	3	0	8	8	2.5%
1	5	2	0	7	15	4.6%
2	0	5	0	5	20	6.2%
3	6	5	2	13	33	10.2%
4	6	5	8	19	52	16.0%
5	3	0	2	5	57	17.6%
6	3	4	8	15	72	22.2%
7	1	8	3	12	84	25.9%
8	3	5	6	14	98	30.2%
9	2	10	7	19	117	36.1%
10	2	12	7	21	138	42.6%
11	1	10	12	23	161	49.7%
12	4	4	7	15	176	54.3%
13	6	10	5	21	197	60.8%
14	4	6	8	18	215	66.4%
15	4	4	4	12	227	70.1%
16	4	4	9	17	244	75.3%
17	9	5	3	17	261	80.6%
18	7	2	2	11	272	84.0%
19	8	1	4	13	285	88.0%
20	4	0	3	7	292	90.1%
21	4	2	0	6	298	92.0%
22	3	1	2	6	304	93.8%
23	5	0	3	8	312	96.3%
24	6	0	1	7	319	98.5%
25	1	0	0	1	320	98.8%
26	0	0	1	1	321	99.1%
27	2	0	1	3	324	100.0%
Total	108	108	108	324	--	--
Average	14.0	10.0	12.0	12.0	--	--
85th Percentile	22.0	15.0	18.0	19.0	--	--
95th Percentile	24.0	18.0	23.0	23.0	--	--
Max	27.0	22.0	27.0	27.0	--	--

**TABLE 11-4
WEEKDAY (FRIDAY) QUEUING ANALYSIS SUMMARY**

Queue Length (Vehicles)	Queue Frequency of Vehicles Observed				Cumulative	
	Site #1 4127 Campus Dr, Irvine, CA	Site #2 31872 Del Obispo St, San Juan Cap, CA	Site #3 31479 Avenue E, Yucaipa, CA	Total	Frequency	Percentage
0	0	3	0	3	3	0.9%
1	0	1	0	1	4	1.2%
2	0	5	2	7	11	3.4%
3	2	4	2	8	19	5.9%
4	1	2	2	5	24	7.4%
5	0	2	6	8	32	9.9%
6	2	5	3	10	42	13.0%
7	4	5	8	17	59	18.2%
8	5	10	5	20	79	24.4%
9	0	10	6	16	95	29.3%
10	6	9	8	23	118	36.4%
11	4	9	9	22	140	43.2%
12	10	7	6	23	163	50.3%
13	6	4	13	23	186	57.4%
14	6	5	6	17	203	62.7%
15	8	7	4	19	222	68.5%
16	5	8	8	21	243	75.0%
17	10	1	4	15	258	79.6%
18	15	2	4	21	279	86.1%
19	6	1	3	10	289	89.2%
20	1	2	0	3	292	90.1%
21	8	1	2	11	303	93.5%
22	3	1	2	6	309	95.4%
23	2	3	1	6	315	97.2%
24	0	0	2	2	317	97.8%
25	1	0	0	1	318	98.1%
26	1	1	0	2	320	98.8%
27	2	0	0	2	322	99.4%
28	0	0	1	1	323	99.7%
29	0	0	0	0	323	99.7%
30	0	0	0	0	323	99.7%
31	0	0	1	1	324	100.0%
Total	108	108	108	324	--	--
Average	15.0	11.0	12.0	12.0	--	--
85th Percentile	21.0	16.0	17.0	18.0	--	--
95th Percentile	23.0	21.0	22.0	22.0	--	--
Max	27.0	26.0	31.0	31.0	--	--

**TABLE 11-5
WEEKEND (SATURDAY) QUEUING ANALYSIS SUMMARY**

Queue Length (Vehicles)	Queue Frequency of Vehicles Observed				Cumulative	
	Site #1 4127 Campus Dr, Irvine, CA	Site #2 31872 Del Obispo St, San Juan Cap, CA	Site #3 31479 Avenue E, Yucaipa, CA	Total	Frequency	Percentage
0	0	6	0	6	6	1.9%
1	3	1	3	7	13	4.0%
2	2	9	1	12	25	7.7%
3	3	4	5	12	37	11.4%
4	2	7	7	16	53	16.4%
5	4	7	7	18	71	21.9%
6	6	6	12	24	95	29.3%
7	4	7	20	31	126	38.9%
8	10	13	4	27	153	47.2%
9	2	3	10	15	168	51.9%
10	6	6	7	19	187	57.7%
11	7	10	5	22	209	64.5%
12	7	9	5	21	230	71.0%
13	10	9	6	25	255	78.7%
14	8	4	5	17	272	84.0%
15	7	2	2	11	283	87.3%
16	4	2	5	11	294	90.7%
17	6	2	1	9	303	93.5%
18	4	1	0	5	308	95.1%
19	3	0	1	4	312	96.3%
20	3	0	1	4	316	97.5%
21	3	0	0	3	319	98.5%
22	2	0	1	3	322	99.4%
23	0	0	0	0	322	99.4%
24	1	0	0	1	323	99.7%
25	0	0	0	0	323	99.7%
26	0	0	0	0	323	99.7%
27	1	0	0	1	324	100.0%
Total	108	108	108	324	--	--
Average	12.0	8.0	9.0	9.0	--	--
85th Percentile	18.0	13.0	13.0	15.0	--	--
95th Percentile	21.0	15.0	16.0	18.0	--	--
Max	27.0	18.0	22.0	27.0	--	--

12.0 RECOMMENDED IMPROVEMENTS

For those intersections where projected traffic volumes are expected to result in impacts, this report recommends traffic improvements that change the intersection geometry to increase capacity. These capacity improvements involve roadway widening and/or re-striping to reconfigure (add lanes) roadways to specific approaches of a key intersection. The identified improvements are expected to:

- Address the impact of existing traffic, Project traffic and future non-project (ambient traffic growth and cumulative) traffic, and
- Improve Levels of Service to an acceptable range and/or to pre-project conditions.

12.1 Project-Specific Improvements

The following project design feature will be constructed by the proposed Project. It should be noted that these improvements were discussed previously in *Section 2.2*.

- Intersection 2. Larch Avenue at Foothill Boulevard: Restripe the westbound right-turn lane on Foothill Boulevard to a westbound shared through/right-turn lane.

12.2 Existing With Project Traffic Conditions

The results of the Existing With Project traffic conditions level of service analyses indicate that the proposed Project ***will not*** impact any of the four (4) key study intersections. The four (4) key study intersections are forecast to operate at acceptable service levels under Existing With Project traffic conditions. As such, no improvement measures addressing LOS have been recommended.

12.3 Existing With Ambient Growth (Year 2025) With Project Traffic Conditions

The results of the Existing With Ambient Growth (Year 2025) With Project traffic conditions level of service analyses indicate that the proposed Project ***will not*** impact any of the four (4) key study intersections. The four (4) key study intersections are forecast to operate at acceptable service levels under Existing With Ambient Growth (Year 2025) With Project traffic conditions. As such, no improvement measures addressing LOS have been recommended.

12.4 Existing With A.G. (Year 2025) With Cumulative With Project Traffic Conditions

The results of the Existing With Ambient Growth (Year 2025) With Cumulative With Project traffic conditions level of service analyses indicate that the proposed Project will impact one (1) of the four (4) key study intersections. The following improvements listed below have been identified to offset the effect of ambient, cumulative, and Project traffic, and improve levels of service to an acceptable range:

- Intersection 2. Larch Avenue at Foothill Boulevard: Install a traffic signal and design for five-phase operation with protected left-turn phasing on Foothill Boulevard. Implement all necessary signing and striping improvements, inclusive of crosswalks for all legs of the intersection.

13.0 FAIR SHARE ANALYSIS

The transportation impacts associated with the development of the proposed Project were determined based on the future conditions analysis with the proposed Project. The key study locations forecast to operate at adverse levels of service are discussed previously in *Section 12.0*. As such, the proposed Project's "fair share" of the recommended improvements has been calculated for the key study locations that are adversely impacted.

13.1 Existing With Ambient Growth With Cumulative With Project Traffic Conditions

Table 13-1 presents the AM and PM Project fair share percentages at the key study intersection that is forecast to operate at adverse levels of service under Existing With Ambient Growth With Cumulative With Project traffic conditions. The first column (1) of *Table 13-1* presents the Project only traffic volumes. The second column (2) presents the existing traffic volumes at the intersection. The third column (3) presents the Existing With Ambient Growth With Cumulative With Project traffic volumes. The fourth column (4) represents the Project fair share based on the following formula:

- Project Fair Share (4) = Column (1)/[Column (3) – Column (2)]*100

The Project fair share percentage (most adverse time period) for the deficient intersection for Existing With Ambient Growth With Cumulative With Project traffic conditions that require recommended improvements are shown below:

- 2. Larch Avenue at Foothill Boulevard 29.75%

TABLE 13-1
EXISTING WITH AMBIENT GROWTH WITH CUMULATIVE WITH PROJECT TRAFFIC CONDITIONS
FAIR SHARE CONTRIBUTION

Key Intersection	Impacted Time Period	(1) Project Only Volume	(2) Existing Volume	(3) Existing With A.G. With Cum. With Project Volume	(4) Project Fair Share Responsibility
2. Larch Avenue at Foothill Boulevard	AM	97	1,351	1,677	29.75%
	PM	72	1,747	2,060	23.00%

Notes:

- Project Fair Share (4) = Column (1) / [Column (3) – Column (2)]
- **Project Fair Share Responsibility** is based on worse case

14.0 VEHICLE MILES TRAVELED (VMT) ASSESSMENT

On December 28, 2018, the California Natural Resources Agency adopted revised CEQA Guidelines. Among the changes to the guidelines was the removal of vehicle delay and LOS from consideration for transportation impacts under CEQA. With the adopted guidelines, transportation impacts are to be evaluated based on a project's effect on vehicle miles traveled. Lead agencies are allowed to continue using their current impact criteria, or to opt into the revised transportation guidelines. However, the new guidelines must be used starting July 1, 2020, as required in CEQA section 15064.3. The City of Rialto recently adopted new traffic impact criteria in October 2021 to be consistent with the CEQA revisions. These new guidelines are contained within the *City of Rialto Traffic Impact Analysis Guidelines for Vehicle Miles Traveled (VMT) and Level of Service Assessment (LOS)*, dated October 2021 and provide screening criteria and methodology for VMT analysis.

Project Screening – Step 3: Project Type Screening of the City's guidelines state that local serving retail projects less than 50,000 square feet may be presumed to have a less than significant impact absent substantial evidence to the contrary. Local serving retail generally improves the convenience of shopping close to home and has the effect of reducing vehicle travel. In addition to local serving retail, the following uses can also be presumed to have a less than significant impact absent substantial evidence to the contrary as their uses are local serving in nature:

- Local-serving K-12 schools
- Local parks
- Day care centers
- Local-serving gas stations
- Local-serving banks
- Local-serving hotels (e.g. non-destination hotels)
- Local-serving medical
- Student housing projects on or adjacent to college campuses
- Local-serving assembly uses (places of worship, community organizations)
- Community institutions (Public libraries, fire stations, local government)
- Local serving community colleges that are consistent with the assumptions noted in the RTP/SCS
- Affordable or supportive housing
- Assisted living facilities
- Senior housing (as defined by HUD)
- 15,000 sq. ft. of light industrial
- 63,000 sq. ft. of warehousing
- 79,000 sq. ft. of high cube transload and short-term storage warehouse

As stated previously in Section 2.0, the proposed Project will consist of a local serving 4,823 SF Chick-fil-A restaurant with drive-through window. Therefore, based on Project Screening – Step 3: Project Type Screening (i.e. local-serving retail projects less than 50,000 square feet), this project would screen out from a VMT analysis and be presumed to have a less than significant impact on VMT, per the City’s guidelines.