

REVISIONS			
NO.	BY:	DESCRIPTION	DATE
1	SP2	REVISED SITE PLAN AND CONCEPTUAL GP TO	11/22
2		ADDRESS CITY COMMENTS DATED 3/18/2022	
3			

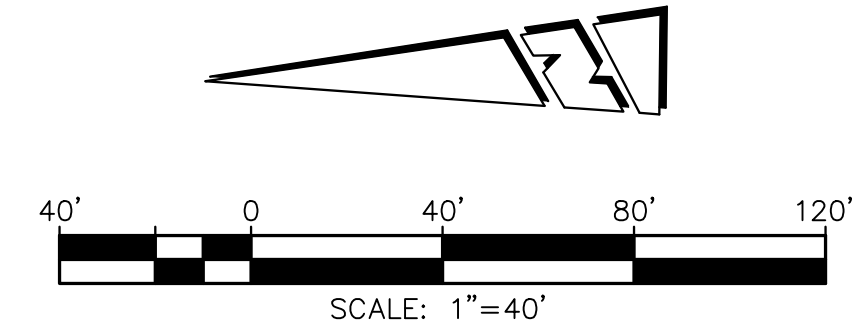

CURVE/LINE DATA

(A) $\Delta=41^{\circ}50'41''$ R=50.00' L=36.52'	(D) $\Delta=73^{\circ}44'23''$ R=50.00' L=50.00'
(B) $\Delta=18^{\circ}15'37''$ R=100.00' L=28.38'	
(C) $\Delta=85^{\circ}33'36''$ R=47.00' L=70.19'	

PUBLIC SERVICE/UTILITY PURVEYORS

SCHOOL DISTRICT: MENEFEE UNION AND PERRIS UNION HIGH
SEWER: EASTERN MUNICIPAL WATER DISTRICT
WATER: EASTERN MUNICIPAL WATER DISTRICT
FIRE PROTECTION: CITY OF MENEFEE
STORM DRAIN: CITY OF MENEFEE/RIVERSIDE COUNTY FLOOD CONTROL AND WATER CONSERVATION DISTRICT
GAS: SOUTHERN CALIFORNIA GAS COMPANY
ELECTRICITY: SOUTHERN CALIFORNIA EDISON COMPANY

FLOOD ZONE DESIGNATION

ZONE "X"
AREAS DETERMINED TO BE OUTSIDE THE 0.2% ANNUAL CHANCE OF FLOOD.
FEMA MAP PANEL #06065C2070H
EFFECTIVE DATE: AUGUST 18, 2014
(SOUTHEAST PORTION OF SITE ZONE AE (EXIST CHANNEL) FLOODWAY AREA IS THE CHANNEL OF A STREAM PLUS ANY ADJACENT FLOODPLAIN AREAS THAT MUST BE KEPT FREE OF ENCROACHMENT SO THAT THE 1% ANNUAL CHANCE FLOOD CAN BE CARRIED WITHOUT INCREASES IN FLOOD HEIGHTS).

LEGEND

- L.A. LANDSCAPE AREA
- T.E. TRASH ENCLOSURE
- S.F. SQUARE FOOTAGE
- P/L PROPERTY LINE
- B.W. BACK OF WALK
- F.S. FINISHED SURFACE
- P/L PROPERTY LINE
- W.Q. WATER QUALITY
- C&G CURB AND GUTTER
- S.C.O. SEWER CLEAN OUT
- C.L.F. CHAIN LINK FENCE
- A.C. ASPHALT CONCRETE PAVEMENT
- R.V. RECREATIONAL VEHICLE
- E.P. EDGE OF PAVEMENT
- S.D. STORM DRAIN
- R/W RIGHT-OF-WAY
- DRWY. CONCRETE APRON DRIVEWAY
- B.S.L. BUILDING SETBACK LINE
- F.H. FIRE HYDRANT
- T.C. TOP OF CURB
- F.L. FLOW LINE
- P.B. PULL BOX
- I.B. IRRIGATION BOX
- C.F. CURB FACE
- Light Standard (OFF-SITE/PUBLIC)
- Fire Hydrant
- Water Valve
- Parking Stall Count
- Tubular Steel Fence
- B.S.L. BUILDING SETBACK LINE
- Prop. Water Line
- Project Boundary
- S.D. STORM DRAIN
- Proposed Building
- Proposed Asphalt Drive
- Exist. Drive (AC Overlay)
- Prop. Off-Site Street Improvements Per Holland Road Overcrossing Plans (Per Project No. CIP 13-03)
- Water Quality Basin
- Prop. Street Light (Per Project No. CIP 13-03)
- ADA Path of Travel
- Proposed 6' (Min.) CMU Wall

EASEMENT NOTES

AN EASEMENT IN FAVOR OF RIVERSIDE COUNTY FLOOD CONTROL AND WATER CONSERVATION DISTRICT, RECORDED SEPTEMBER 29, 2011, AS INSTRUMENT NO. 2011-0431491, O.R.

SITE PLAN

"STAXUP STORAGE EXPANSION"

IN THE CITY OF MENEFEE, COUNTY OF RIVERSIDE, STATE OF CALIFORNIA

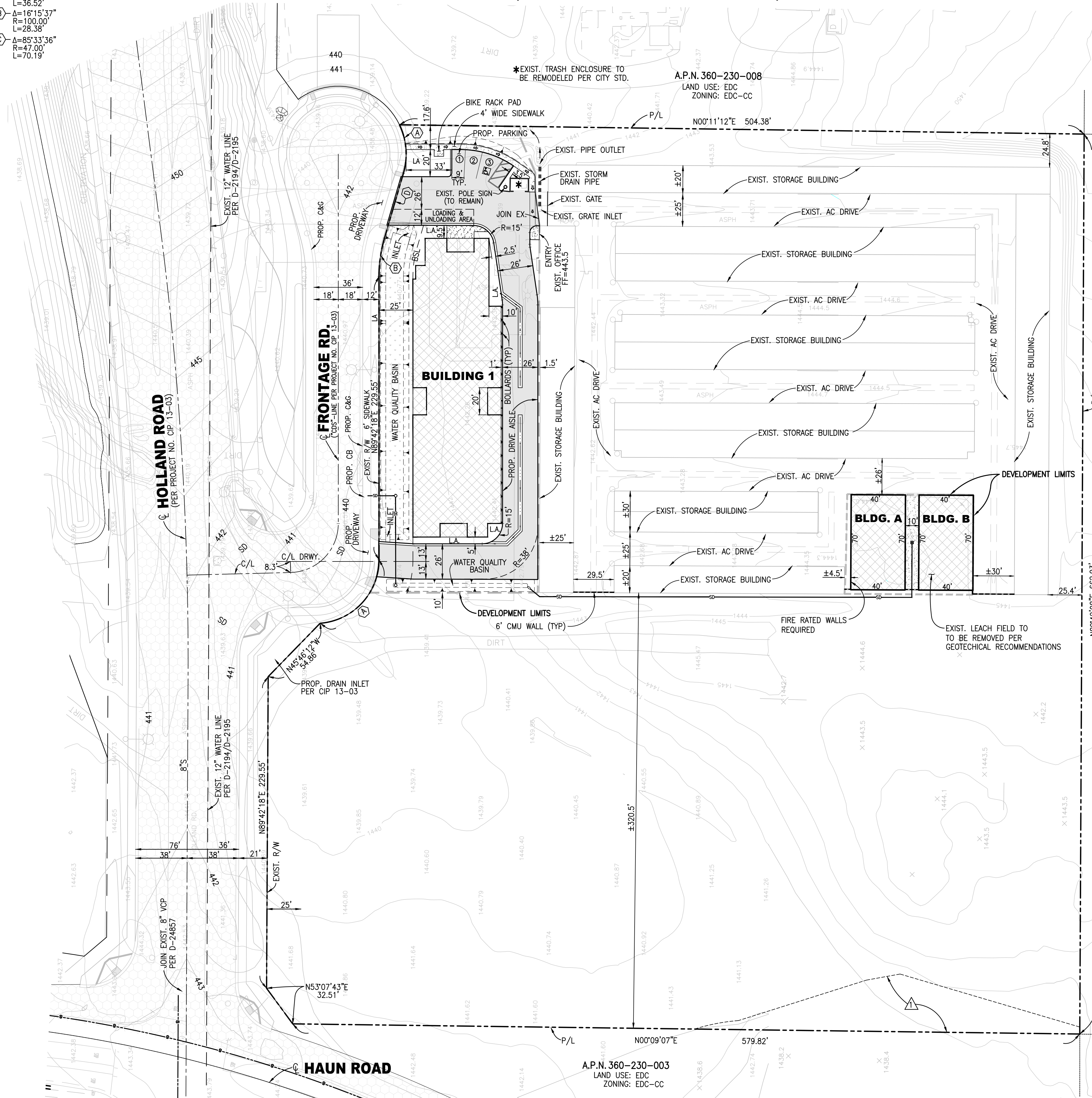
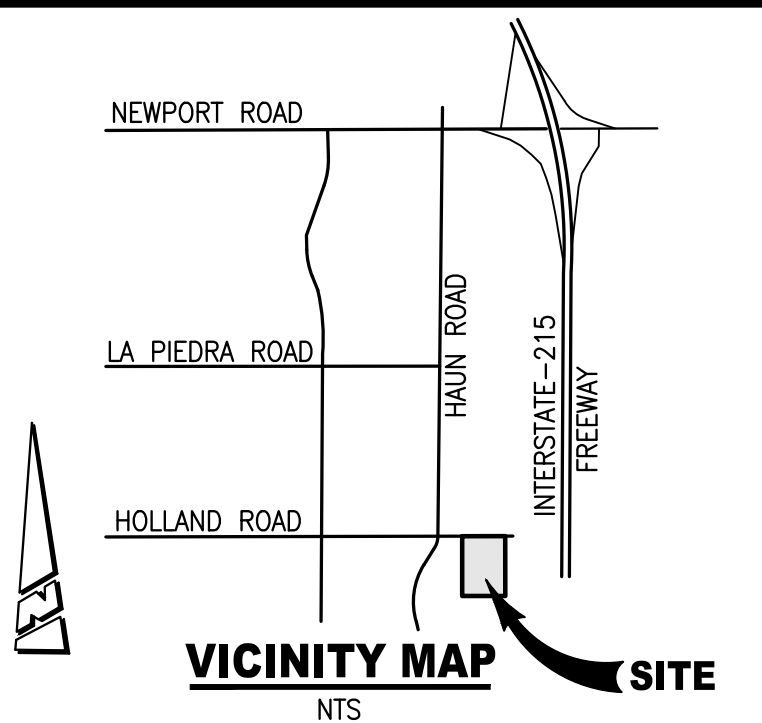

A.P.N. 360-230-010
LAND USE: EDC
ZONING: EDC-CC

A.P.N. 360-230-009
LAND USE: EDC
ZONING: EDC-CC

A.P.N. 360-230-006
LAND USE: EDC
ZONING: EDC-CC

LEGAL DESCRIPTION

THE NORTHWEST QUARTER OF THE NORTHEAST QUARTER OF SECTION 10, TOWNSHIP 6 SOUTH, RANGE 3 WEST, OF THE SAN BERNARDINO BASELINE AND MERIDIAN, IN THE CITY OF MENEFEE, COUNTY OF RIVERSIDE, STATE OF CALIFORNIA ACCORDING TO THE OFFICIAL PLAT THEREOF AND MORE PARTICULARLY DESCRIBED AS FOLLOWS:

COMMENCING AT THE NORTHEAST CORNER OF SECTION 10, TOWNSHIP 6 SOUTH, RANGE 3 WEST, OF THE SAN BERNARDINO BASELINE AND MERIDIAN;

THENCE ALONG THE NORTH LINE OF SAID SECTION 10, SOUTH 89°42'18" WEST, A DISTANCE OF 663.30 FEET, TO THE NORTHEAST CORNER OF SAID NORTHWEST QUARTER AND THE TRUE POINT OF BEGINNING;

THENCE CONTINUING ALONG SAID NORTH LINE, SOUTH 89°42'18" WEST, A DISTANCE OF 663.30 FEET, TO THE NORTHWEST CORNER OF SAID NORTHWEST QUARTER;

THENCE LEAVING SAID NORTH LINE AND ALONG THE WEST LINE OF SAID NORTHWEST QUARTER, SOUTH 00°09'13" WEST, A DISTANCE OF 658.20 FEET, TO THE SOUTHWEST CORNER OF SAID NORTHWEST QUARTER;

THENCE ALONG THE SOUTH LINE OF SAID NORTHWEST QUARTER, NORTH 89°41'55" EAST, A DISTANCE OF 662.93 FEET, TO THE SOUTHEAST CORNER OF SAID NORTHWEST QUARTER;

THENCE ALONG THE EAST LINE OF SAID NORTHWEST QUARTER, NORTH 00°11'09" EAST, A DISTANCE OF 658.13 FEET, TO THE TRUE POINT OF BEGINNING;

EXCEPT THEREFROM THAT PORTION DESCRIBED IN THE DEED TO THE CITY OF MENEFEE, A MUNICIPAL CORPORATION, RECORDED AUGUST 31, 2020, AS INSTRUMENT NO. 2020-0407693, OF OFFICIAL RECORDS.

PROPERTY CONTAINS: 8.40 ACRES (365,862 S.F.)
PROPOSED DEVELOPMENT FOOTPRINTS CONTAINS: 1 ACRE, MORE OR LESS

DEVELOPMENT STANDARDS (*)

- SETBACKS PER EDC-CC:
 - MINIMUM NET LOT AREA (SQ. FT): 15,000
 - MAXIMUM FLOOR AREA RATIO: 1.0
- SETBACK CRITERIA:
 - FRONT YARD: 25'
 - INTERIOR SIDE YARD: 0
 - STREET SIDE YARD: 15'
 - REAR YARD: 15'
- MAXIMUM BUILDING HEIGHT (FT): 75
- MAXIMUM BUILDING COVERAGE: -
- MINIMUM LANDSCAPE OPEN SPACE REQUIRED (%): 10
- REQUIRED PARKING: 2 SPACES PER 3 EMPLOYEES (SELF STORAGE USE)
- PARKING PROVIDED: 7 STD., 1 HANDICAP, AND LOADING AREA
- (*) PER TABLE 9.140.040-2 ECONOMIC DEVELOPMENT CORRIDOR ZONES

GENERAL MAP NOTES

1. PREPARED: 2-7-2022 (REVISED 1/19/2023)
2. ASSESSOR'S PARCEL NUMBER: 360-230-019
3. SITE ZONING DESIGNATION:
 - ECONOMIC DEVELOPMENT CORRIDOR-COMMUNITY CORE (EDC-CC)
4. SITE GENERAL PLAN LAND USE DESIGNATION:
 - ECONOMIC DEVELOPMENT CORRIDOR (EDC)
5. EXISTING/PROPOSED LAND USE:
 - SELF STORAGE
6. NO OFF-SITE RIGHT-OF-WAY IS REQUIRED FOR SITE ACCESSIBILITY.
7. THIS MAP INCLUDES THE ENTIRE CONTIGUOUS OWNERSHIP OF THE LAND DIVIDER.
8. IN LIEU OF A FIRE SPRINKLER SYSTEM, PROPOSED BUILDINGS A-B WILL BE CONSTRUCTED WITH INTERIOR FIRE RATED WALLS IN ACCORDANCE WITH THE CITY OF MENEFEE FIRE CODE.
9. PRELIMINARY EARTHWORK QUANTITIES (EXCLUDED REMEDIAL GRADING):
 - CUT: 2,000 C.Y. / FILL: 2,000 C.Y.
10. SEWER AND WATER SERVICE FOR THE SITE WILL BE PROVIDED BY E.M.W.D.
11. THE SITE IS NOT WITHIN A EARTHQUAKE FAULT ZONE.
12. THE SITE HAS A LOW LIQUEFACTION POTENTIAL.
13. THE SITE IS NOT WITHIN A COUNTY SERVICE AREA (CSA).
14. THE SITE MAP INCLUDES THE ENTIRE CONTIGUOUS OWNERSHIP OF THE LAND DIVIDER.
15. THE SITE IS DESIGNATED AS NON-VERY HIGH FIRE HAZARD SEVERITY ZONE (NON-VHFHSZ) PER CAL FIRE HAZARD SEVERITY ZONE MAP ID: FHSZL_C33_MENEFEE
16. PROPOSED DEVELOPMENT FOOTPRINT: ±1 AC
17. THERE ARE NO KNOWN WELLS WITHIN 200' OF PROPERTY.
18. GROSS/NET AREA: 8.40 ACRES
19. PARKING COUNT: 2 STANDARD STALLS /1 HANDICAP STALL
20. NUMBER OF EMPLOYEES: 1-FULL TIME
21. BUILDING AREAS:
 - EXISTING: 53,325 SF (INCLUDES ± 500 SF OFFICE)
 - BUILDING 1: 31,040-SF-BUILDING A: 2,800 SF-BUILDING B: 2,800 SF
22. LANDSCAPING WITHIN BUILDING R/W ALONG PROJECT FRONTAGE TO BE MAINTAINED BY PROPERTY.

OWNER/APPLICANT:
MENEFEE STORAGE, LP/ STRAT PROPERTY MANAGEMENT, INC.
2055 3RD AVENUE #200
SAN DIEGO, CA 92101
OFFICE PH: 619-295-2211
CONTACT: BRANDON LOFTUS
EMAIL: BLOFTUS@STRATPROP.COM

PREPARED BY:
STEVENSON, PORTO & PIERCE, INC.
LAND DEVELOPMENT SERVICES COMPANY
451 W. LAMBERT RD. SUITE 216
BREA, CALIFORNIA 92821
PHONE: (714) 490-1514
CONTACT: HENRY LOZANO
EMAIL: HENRY@SP2INC.COM

INDEX OF SHEETS

- SHEET 1: SITE PLAN
- SHEET 2: CONCEPTUAL GRADING AND UTILITY PLAN

CONCEPTUAL GRADING & UTILITY PLAN

"STAXUP STORAGE EXPANSION"

IN THE CITY OF MENIFEE, COUNTY OF RIVERSIDE, STATE OF CALIFORNIA

A.P.N. 360-230-008

LEGEND

- EX. EXISTING
 - G.I. GRATE INLET
 - L.A. LANDSCAPE AREA
 - T.E. TRASH ENCLOSURE
 - S.F. SQUARE FOOTAGE
 - P/L PROPERTY LINE
 - B.W. BACK OF WALK
 - F.S. FINISHED SURFACE
 - P/L PROPERTY LINE
 - W.Q. WATER QUALITY
 - C&G CURB AND GUTTER
 - S.C.O. SEWER CLEAN OUT
 - C.L.F. CHAIN LINK FENCE
 - A.C. ASPHALT CONCRETE PAVEMENT
 - R.V. RECREATIONAL VEHICLE
 - E.P. EDGE OF PAVEMENT
 - S.D. STORM DRAIN
 - R/W RIGHT-OF-WAY
 - DR.W. CONCRETE APRON DRIVEWAY
 - B.S.L. BUILDING SETBACK LINE
 - F.H. FIRE HYDRANT
 - T.C. TOP OF CURB
 - F.L. FLOW LINE
 - P.B. PULL BOX
 - I.B. IRRIGATION BOX
 - C.F. CURB FACE
 - ON-SITE LIGHT PEDESTAL
 - FIRE HYDRANT
 - WATER VALVE
 - TUBULAR STEEL FENCE
 - BSL BUILDING SETBACK LINE
 - W PROP. WATER LINE
 - PROJECT BOUNDARY
 - S.D. STORM DRAIN
-
- SECTION REFERENCE
 - PAGE NUMBER
 - PROPOSED BUILDING
 - PROPOSED ASPHALT DRIVE
 - EXIST. DRIVE (AC OVERLAY)
 - PROP. OFF-SITE STREET IMPROVEMENTS PER HOLLAND ROAD OVERCROSSING PLANS (PER PROJECT NO. CIP 13-03)
 - WATER QUALITY BASIN
 - PROP. STREET LIGHT (PER PROJECT NO. CIP 13-03)

IMPROVEMENT NOTES

- 1 ASPHALT PAVING PER GEOTECHNICAL RECOMMENDATIONS
- 1A ASPHALT OVERLAY PER GEOTECHNICAL RECOMMENDATIONS
- 2 PROPOSED 6" (TYPE "D") CURB PER R.C.T.D. PER R.C.T.D. STD. 204.
- 3 PROPOSED 6" (TYPE "A-6") CURB AND GUTTER PER R.C.T.D. STD. 200.
- 4 PROPOSED COMMERCIAL DRIVEWAY PER CIP PROJECT 13-03
- 5 PROPOSED 6' WIDE SIDEWALK (AT CURB) PER CIP PROJECT 13-03
- 6 3' CONCRETE RIBBON GUTTER
- 7 PROPOSED 4" PCC SIDEWALK (4' WIDE MIN.)

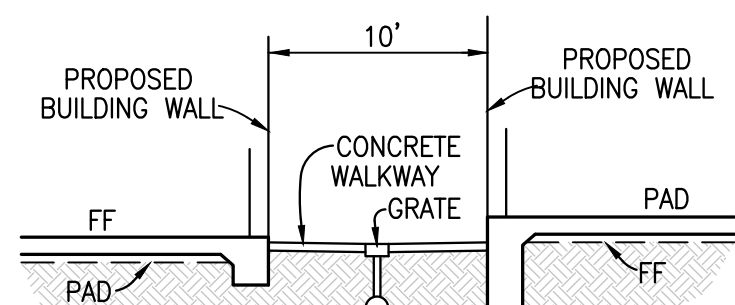

TYP. SECTION "E"

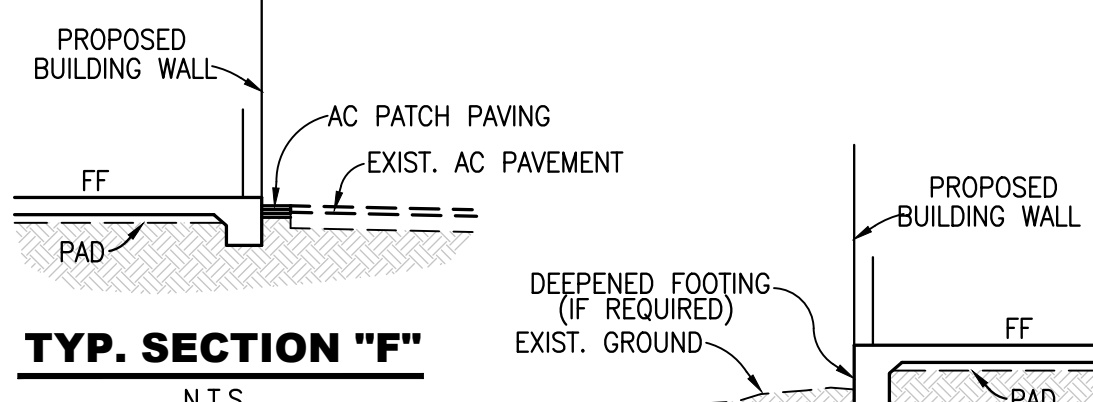

TYP. SECTION "F"

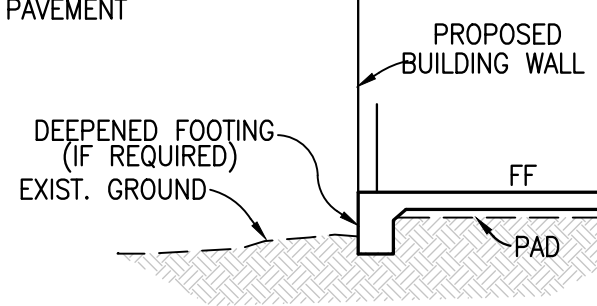

TYP. SECTION "J"

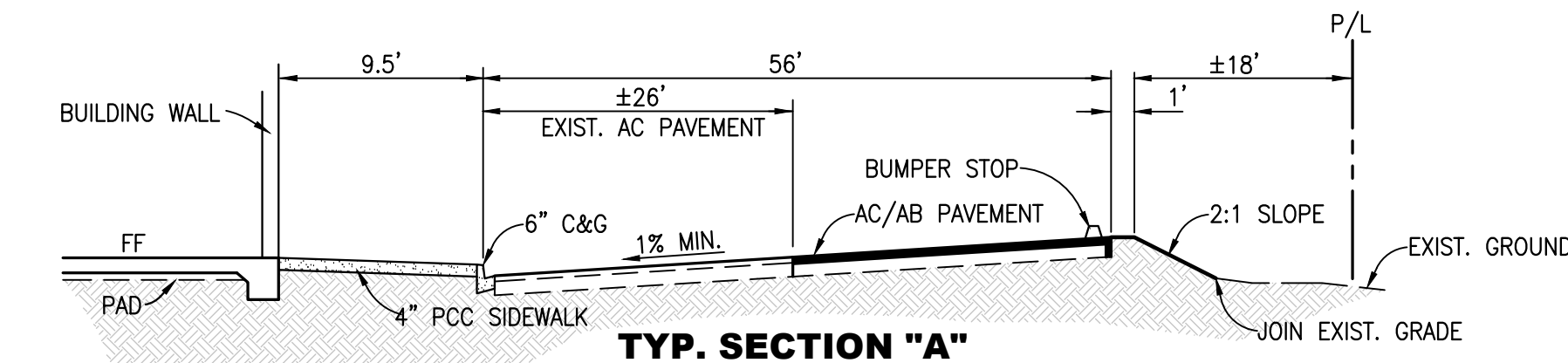
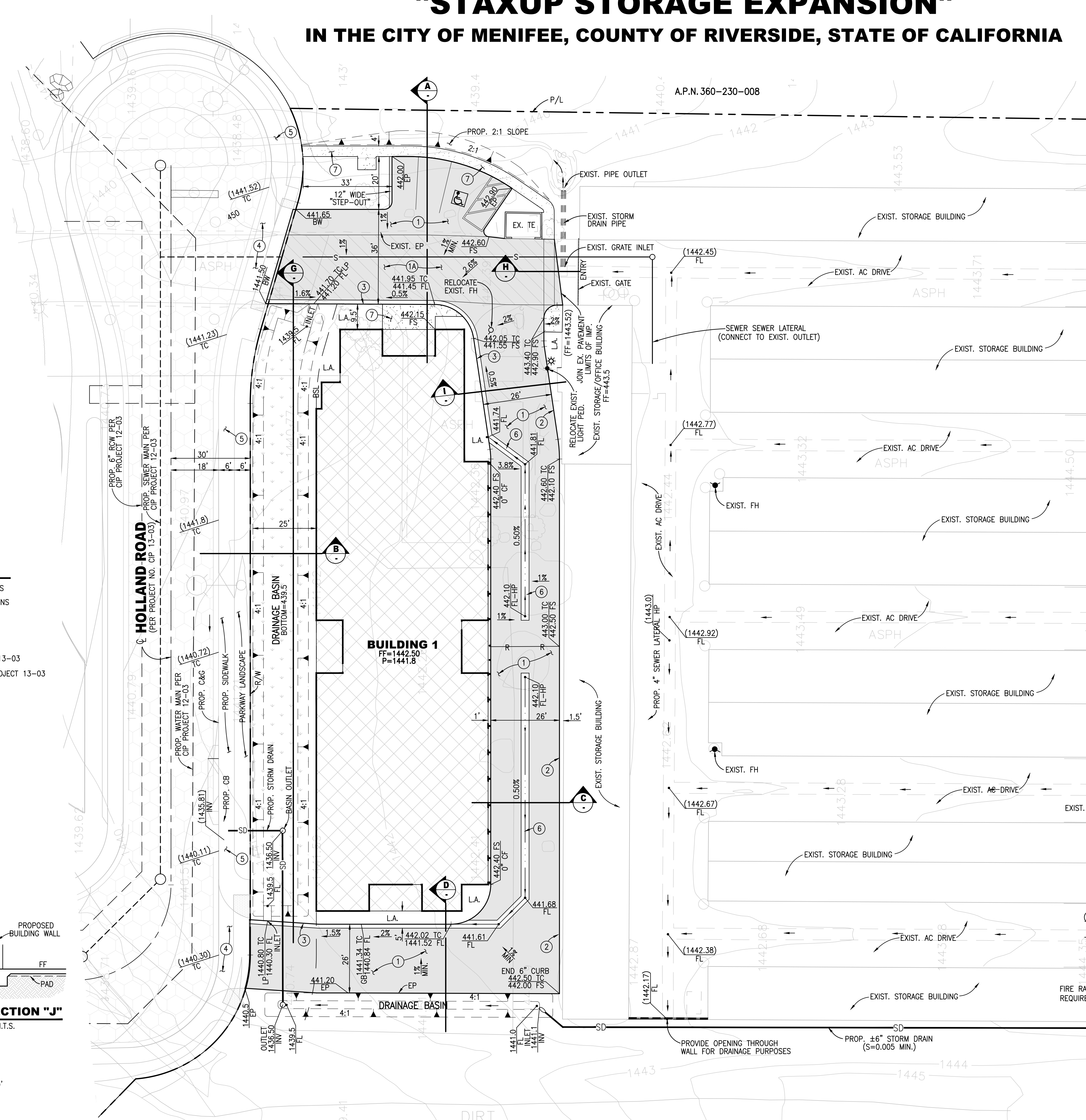
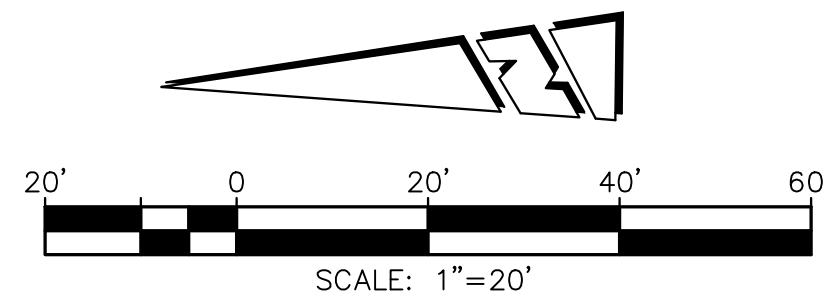

TYP. SECTION "A"

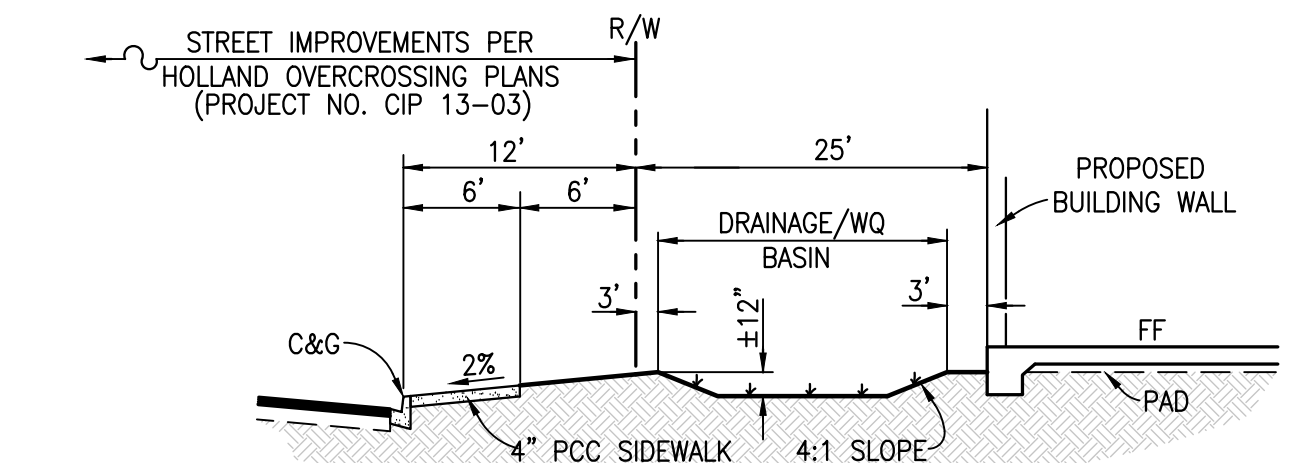

TYP. SECTION "B"

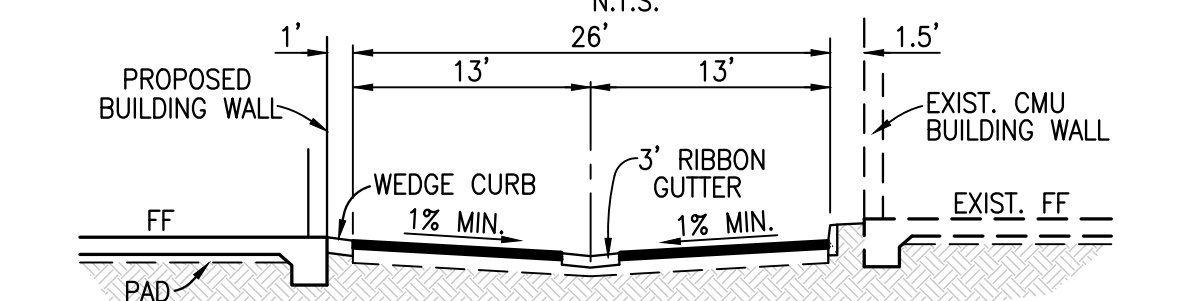

TYP. SECTION "C"

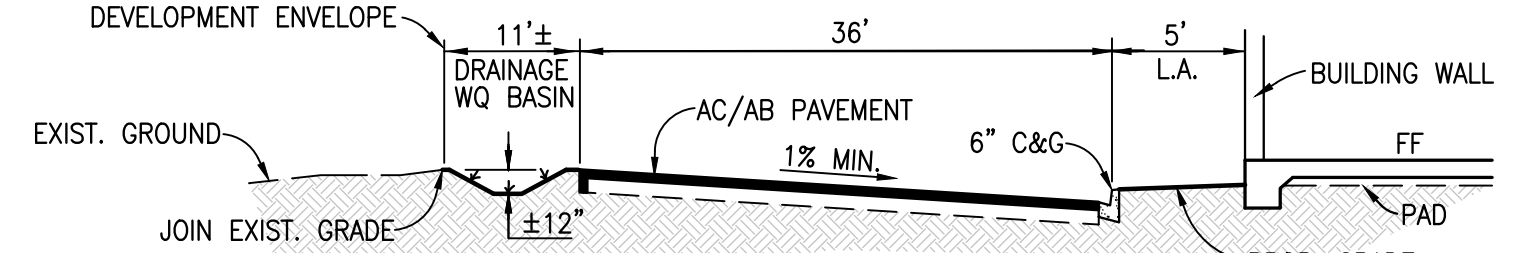

TYP. SECTION "D"

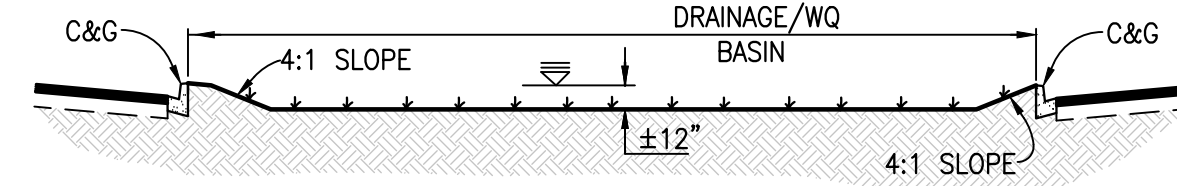

TYP. SECTION "G"

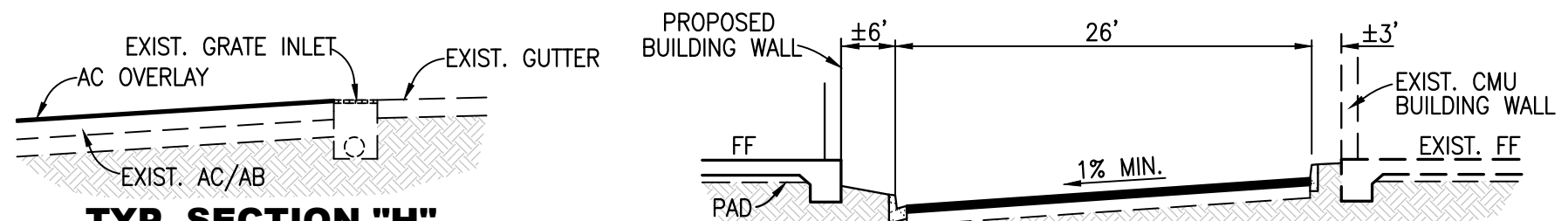

TYP. SECTION "H"



TYP. SECTION "I"